

FEATURES

- Fits on NEMA 34 & 42
- Perfect for Holding Applications
- Handles High Torque
- Compact Size
- Operates On Low Voltage



DESCRIPTION

Perfect for holding applications, these friction brakes can handle high torque with a compact size. The low voltage design will operate on applications susceptible to weak battery, brown out or long wiring runs. When the electric power is applied, the armature is pulled by the electromagnetic force in the magnet body assembly, which overcomes the spring action. This allows the friction disc to rotate freely. When electrical power is interrupted, the electromagnetic force is removed and the pressure spring mechanically forces the armature plate to clamp the friction disc between itself and the pressure plate. This develops torque to hold the load.

SPECIFICATIONS

Model #	Fits NEMA Size	Bore Size (in)	Maximum Torque (oz-in)	Maximum Torque (in-lb)	Electric Power (Watts)	Current (mA)	Voltage (V)	Diameter (in)	Width (in)	Weight (lbs)
BRK-28H-1150-024-315	34 & 42	0.315	1152	72	17	670	24	3.25	1.415	1.92
BRK-28H-1150-024-375	34 & 42	0.375	1152	72	17	670	24	3.25	1.415	1.92
BRK-28H-1150-024-472	34 & 42	0.472	1152	72	17	670	24	3.25	1.415	1.92
BRK-28H-1150-024-500	34 & 42	0.500	1152	72	17	670	24	3.25	1.415	1.92

L010464

Brake

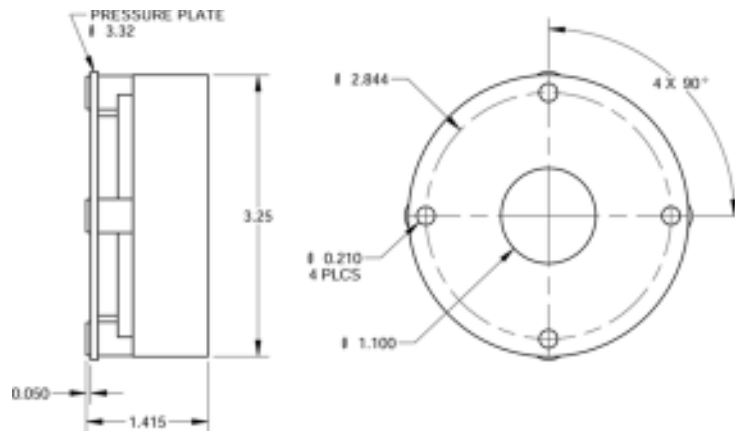

*Note: Units are in inches

Brake Attached to Nema 34 Frame Motor

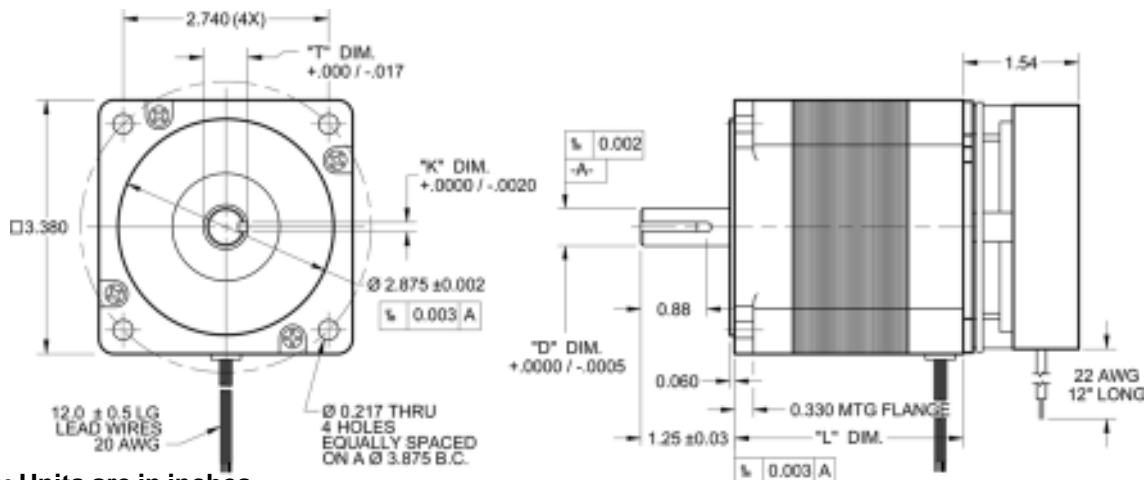

*Note: Units are in inches

Brake Attached to Nema 42 Frame Motor

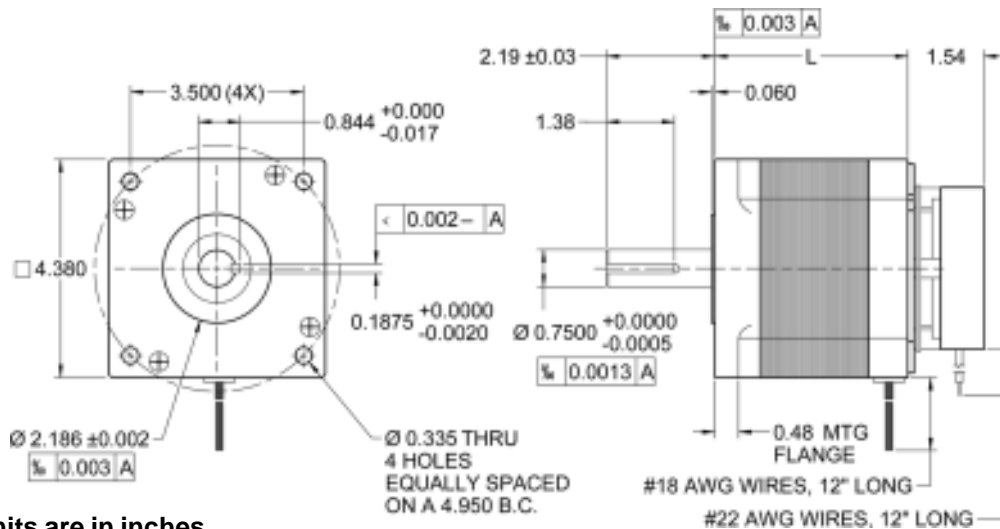

*Note: Units are in inches