

MDC150-050301

50V, 30A Brushless Controller

User's Guide



ANAHEIM AUTOMATION

910 East Orangefair Lane, Anaheim, CA 92801
e-mail: info@anaheimautomation.com

(714) 992-6990 fax: (714) 992-0471
website: www.anaheimautomation.com

MDC150-050301 Driver Features

- Maximum Current Limit Setting from 10.0-30.0 Amps (peak)
- Internal or External Potentiometer Speed Control
- 2-Quadrant Operation
- Hall Sensor Feedback
- Constant Velocity Mode
- Short Circuit Protection
- Requires 20-50 VDC
- Speed Out
- Fault Out
- Brake, Disable and Direction Inputs
- Selectable Ramp Up/Down
- TTL-CMOS Compatible Inputs
- Compact Size (5.25" x 3.06" x 1.65")
- Dual Mounting Option
- Detachable, Screw Type Terminal Block

General Description

The MDC150-050301 driver is designed to drive DC brushless motors at currents of up to 30A (peak) and 50V. Using hall sensor feedback, a constant velocity mode can be selected. The driver is protected against over current (cycle-by-cycle or latched), hall sensor error and under voltage. When an error occurs, a fault light is turned on to notify the user. Included on the driver is an internal potentiometer to control the maximum phase current allowed into the motor and an internal potentiometer to control the speed of the motor. An optional external potentiometer (10K) or external voltage (1-4VDC) can be used to control the speed as well. The direction of the motor can be preset by the direction control input. Other inputs to the drive include a run/stop and a motor freewheel input. When using the run/stop input, there are three ramp up profiles from standstill to select from. The run/stop input overrides all other inputs into the driver.

Fault Protection

Over current protection can be provided by means of a over current latch function by setting the 'FLT LATCH' dip switch on. If a motor current level exceeding the current limit set by the internal or external current limit potentiometer is produced, an over current latch is activated, shutting off the output. When a fault is detected, the driver turns off the motor current, the red FAULT LED alerts the user a fault occurred and the Fault Output (TB3 - Pin 5) goes low. The Fault Output is disabled, logic '1' output, when the 'FLT LATCH' dip switch is in the off position and disabled. This Fault protection alerts the user of the following conditions.

1. Invalid Sensor Input Code
2. Over Current. The driver is equipped with cycle-by-cycle current limiting or over current latch.
3. Undervoltage Lockout activation at 9.1 VDC for the input voltage and 4.5 VDC for the Hall Sensor voltage.

Ordering Information

Part #	Description
MDC150-050301	Featured BLDC driver 30A, 50V
PSA24V2.7A	DC Power Supply 24VDC at 2.7 Amps
PSA40V4A	DC Power Supply 40VDC at 4 Amps
PSA40V8A	DC Power Supply 40VDC at 8 Amps
CBL-AA5420	Cable, 3 Pins 12in. Long, For External Pot

Specifications

Control Inputs: (TB3, Pins 2-4)

TTL-CMOS Compatible

Logic "0" = 0-0.8VDC

Logic "1" = OPEN

All three inputs (run/stop, freewheel and direction) are pulled up to through 20k ohm resistors.

Freewheel: (TB3, Pin 3)

Logic "1" (open) - Motor is Enabled

Logic "0" - Motor is de-energized and will coast

Direction Control: (TB3, Pin 2)

Logic "1" (open) - Clockwise

Logic "0" - Counterclockwise

Run/Stop: (TB3, Pin 4)

Logic "1" (open) - Motor will not run and if running will come to a hard stop

Logic "0" - Motor will run and will accelerate according to ramp dip switch setting

Fault Output: (TB3, Pin 5)

Logic "1" (5V out) - Status good, normal operation.

Logic "0" - One of the three fault conditions listed in the 'Fault Protection' section has occurred.

Speed Output: (TB3, Pin 1)

A 5V signal pulse out is available at a rate of 4 pulses for 1 revolution of an 8-pole motor, 3 pulses for 1 revolution of a 6-pole motor, and 2 pulses for 1 revolution of a 4-pole motor.

8-pole motor RPM = 15 * PG OUT (in Hz)

6-pole motor RPM = 20 * PG OUT (in Hz)

4-pole motor RPM = 30 * PG OUT (in Hz)

Output Current Rating:

Adjustable 10.0 - 30.0 amperes per phase maximum operating peak current

(5.0 - 15.0 amperes per phase maximum operating continuous current)

Power Requirements: (TB2, Pins 1 and 2)

20VDC (min) - 50VDC (max)

Operating Temperature

Heat Sink: 0°-70° C

Hall Sensor Power Output:

6.25V @30mA maximum. Typical current draw from hall sensors in 20mA.

All three Hall Sensor inputs are pulled up through 20K ohm resistors.

The external speed control potentiometer must be 10K Ohms.

Heating Considerations

The temperature of the heat sink should never be allowed to rise above 70° C. If necessary, mount the unit to an additional heat sink or air should be blown across the heat sink to maintain suitable temperatures.

Commutation Sequence

	Step					
	1	2	3	4	5	6
Phase A	+	Z	-	-	Z	+
Phase B	Z	+	+	Z	-	-
Phase C	-	-	Z	+	+	Z
Hall A	1	1	0	0	0	1
Hall B	0	1	1	1	0	0
Hall C	0	0	0	1	1	1

120° Hall Spacing Sequence Forward

	Step					
	1	2	3	4	5	6
Phase A	+	Z	-	-	Z	+
Phase B	Z	+	+	Z	-	-
Phase C	-	-	Z	+	+	Z
Hall A	1	1	0	0	0	1
Hall B	0	1	1	1	0	0
Hall C	0	0	0	1	1	1

120° Hall Spacing Sequence Reverse

	Step					
	1	2	3	4	5	6
Phase A	+	Z	-	-	Z	+
Phase B	Z	+	+	Z	-	-
Phase C	-	-	Z	+	+	Z
Hall A	1	1	0	0	0	1
Hall B	0	1	1	1	0	0
Hall C	0	0	0	1	1	1

60° Hall Spacing Sequence Forward

	Step					
	1	2	3	4	5	6
Phase A	+	Z	-	-	Z	+
Phase B	Z	+	+	Z	-	-
Phase C	-	-	Z	+	+	Z
Hall A	1	1	0	0	0	1
Hall B	0	1	1	1	0	0
Hall C	0	0	0	1	1	1

60° Hall Spacing Sequence Reverse

+ = Top Transistor ON, Bottom Transistor OFF, Current flows into this wire

- = Top Transistor OFF, Bottom Transistor ON, Current flows out of this wire

Z = Top Transistor OFF, Bottom Transistor OFF, No current into or out of this wire (High Impedance)

Motor Connection

Refer to the hookup diagram for typical driver applications. When connecting a motor for the first time, connect the hall sensor wires (5 of them) to the driver. **DO NOT CONNECT THE PHASES YET.** Turn on power and rotate the motor by hand. If the RED FAULT LED comes on, the hall phases are incorrectly wired. If the RED FAULT LED does not come on then the hall wires are connected correctly. Power the unit down and proceed to connect the motor phases. If the motor does not run or runs erratically, power down and check the speed potentiometer and make sure the phases are connected correctly. There are six different ways to connect the phase wires, and normally only two will allow the motor to rotate, but only one is correct. If the direction of the motor is changed and the no-load current of the motor is approximately the same and the motor runs smoothly in both directions then the phase wires are correct.

The wiring of the motor phases should be separated from the hall and input connections to not allow a possible source of interference.

Terminal and Dip Switch Descriptions

Pin #	Description
1	Hall Sensor Power
2	Hall Sensor A
3	Hall Sensor B
4	Hall Sensor C
5	Hall Sensor Ground

TB1: Motor Hall Terminals

Pin #	Description
1	Power In (20-50VDC)
2	Ground
3	Phase C
4	Phase B
5	Phase A

TB2: Power and Motor Phase Terminals

Pin #	Description
1	PG OUT
2	Direction
3	Freewheel
q	Run/Stop
5	Fault Out
6	GND

TB3: Control Inputs and Outputs

Pin #	Description
1	+4.0V (Pot Top)
2	Pot Wiper
3	+1.0V (Pot Bottom)

P1: 10K External Pot

SW #	Description
1	O/C LOOP
2	FLT LATCH
3	RAMP 1
4	RAMP 2
5	60/120

SW: Dip Switch

Dip Switch and Jumper Settings

Function	SW1	SW2	SW3	SW4	SW5	JP2
Constant Speed Mode (Closed Looped)	Off	---	---	---	---	---
Voltage Controlled Speed Mode (Open Loop)	On	---	---	---	---	---
Over Current Latching	---	On	---	---	---	---
Over Current Cycle by Cycle	---	Off	---	---	---	---
Ramp Profile 1 (4 Sec)	---	---	Off	Off	---	---
Ramp Profile 2 (2 Sec)	---	---	Off	On	---	---
Ramp Profile 3 (1 Sec)	---	---	On	Off	---	---
Ramp Profile 4 (500mSec)	---	---	On	On	---	---
60° Hall Sensor Spacing	---	---	---	---	Off	---
120° Hall Sensor Spacing	---	---	---	---	On	---
Internal Speed Control (JP2)	---	---	---	---	---	1-2
External Speed Control (JP2)	---	---	---	---	---	2-3
Standard Product (Ready to Ship)	Off	Off	Off	Off	On	1-2

Motor Freewheel

The motor freewheel feature allows the de-energizing of the motor phases. A high (open) input at this input causes the motor to run at the given speed, while a low at this input causes the motor to coast to a stop.

Motor Run/Stop

The motor run/stop feature allows the stopping of a motor by shorting out the bottom drives of the three phases. A low at this input allows the motor to run, while a high (open) input does not allow motor operation and if operating causes rapid deceleration.

Motor Direction

The motor direction feature allows the changing of the rotation of the motor. This input should not be changed while motion is in progress. A high (open) input causes the motor to turn in the CW direction, while a low at this input causes the motor to turn in the CCW direction.

Speed Adjust Setting

There are two ways to set the speed on this drive. One is to use the on board potentiometer. The other is to use an external 10K potentiometer. To use the on board potentiometer, set jumper JP2 to position 1-2 (default). To use the external 10K potentiometer or external 1V to 4V voltage speed setting, remove cover and set jumper JP2 to position 2-3. A voltage of 1V-4V to control the speed of the motor can be tied to the Pot Wiper connection of P1 with 0V tied to pin 6 of TB3 (GND). The maximum voltage that can be placed on the pot wiper with respect to ground is 6V.

The mating connector for the external 10K potentiometer is Molex part number 3-640440-3.

Speed Output

The PG OUT terminal (TB3 - pin 1) is used to determine the speed of the motor shaft. A 5V signal pulse out is shown at a rate of 4 pulses for 1 revolution of an 8-pole motor, 3 pulse for 1 revolution of a 6-pole motor, and 2 pulses for 1 revolution of a 4-pole motor.

# Poles	RPM
8	15 * PG OUT (in Hz)
6	20 * PG OUT (in Hz)
4	30 * PG OUT (in Hz)

Fault Output

The Fault Output is only active when the Fault Latch is enabled, setting the 'FLT LATCH' dip switch on. The TTL level Fault Output indicates an over current or failure in the motor/driver operation. The Fault Output is normally at a TTL logic level 1. If a fault occurs, the Fault Output will go to a TTL logic level 0.

Typical Hookup Drawing

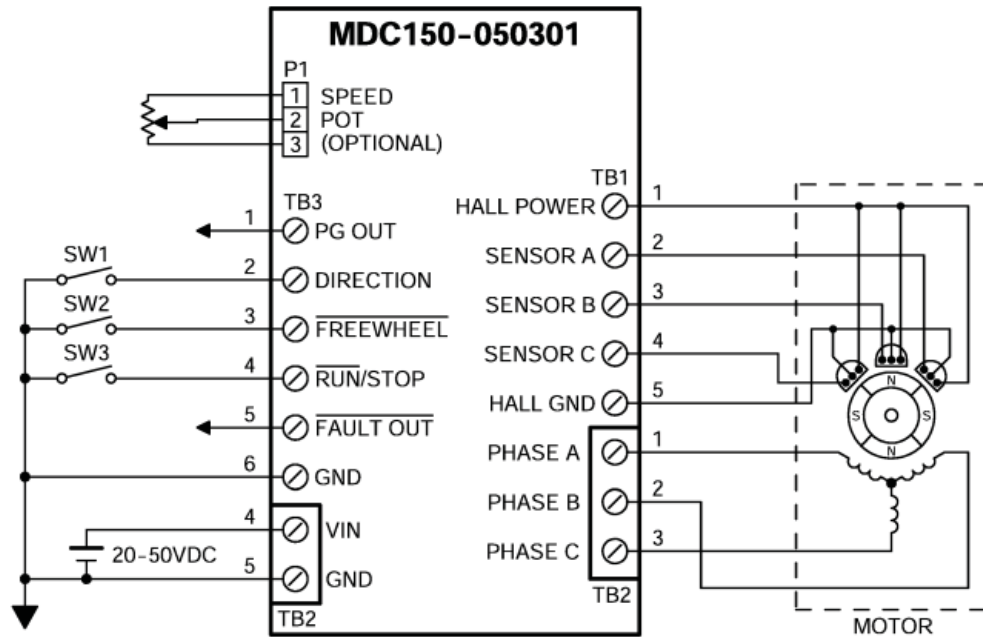

Dimensions

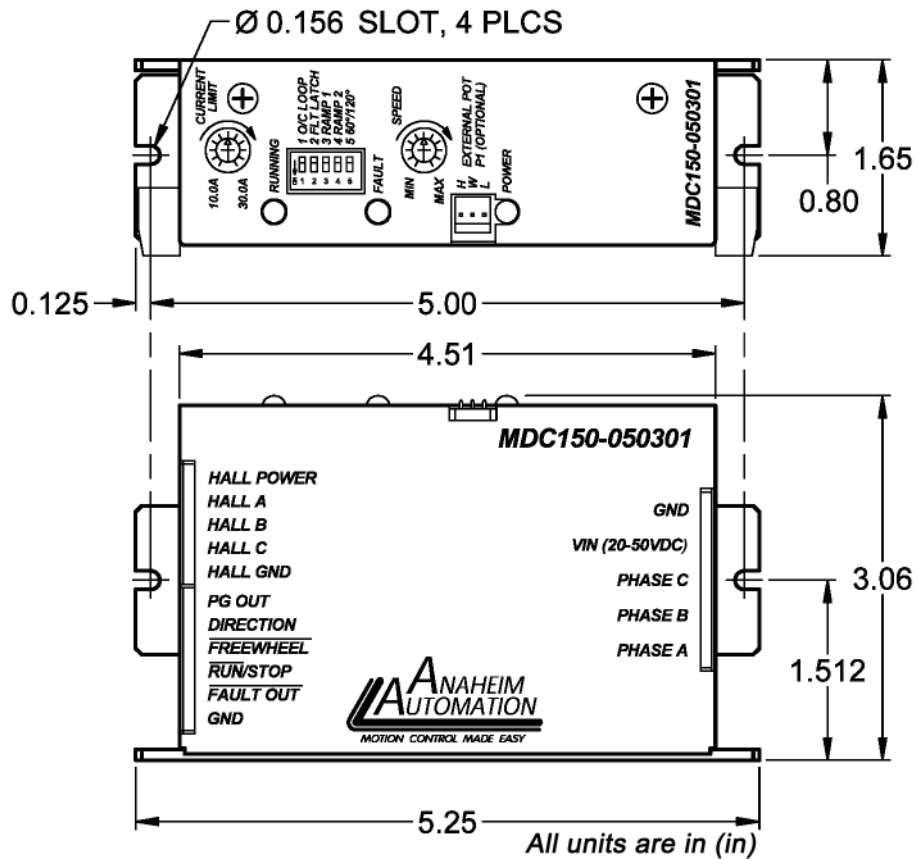

COPYRIGHT

Copyright 2007 by Anaheim Automation. All rights reserved. No part of this publication may be reproduced, transmitted, transcribed, stored in a retrieval system, or translated into any language, in any form or by any means, electronic, mechanical, magnetic, optical, chemical, manual, or otherwise, without the prior written permission of Anaheim Automation, 910 E. Orangefair Lane, Anaheim, CA 92801.

DISCLAIMER

Though every effort has been made to supply complete and accurate information in this manual, the contents are subject to change without notice or obligation to inform the buyer. **In no event will Anaheim Automation be liable for direct, indirect, special, incidental, or consequential damages arising out of the use or inability to use the product or documentation.**

Anaheim Automation's general policy does not recommend the use of its' products in life support applications wherein a failure or malfunction of the product may directly threaten life or injury. Per Anaheim Automation's Terms and Conditions, the user of Anaheim Automation products in life support applications assumes all risks of such use and indemnifies Anaheim Automation against all damages.

LIMITED WARRANTY

All Anaheim Automation products are warranted against defects in workmanship, materials and construction, when used under Normal Operating Conditions and when used in accordance with specifications. This warranty shall be in effect for a period of twelve months from the date of purchase or eighteen months from the date of manufacture, whichever comes first. **Warranty provisions may be voided if products are subjected to physical modifications, damage, abuse, or misuse.**

Anaheim Automation will repair or replace at its' option, any product which has been found to be defective and is within the warranty period, provided that the item is shipped freight prepaid, with previous authorization (RMA#) to Anaheim Automation's plant in Anaheim, California.

TECHNICAL SUPPORT

If you should require technical support or if you have problems using any of the equipment covered by this manual, please read the manual completely to see if it will answer the questions you have. If you need assistance beyond what this manual can provide, contact your Local Distributor where you purchased the unit, or contact the factory direct.

ANAHEIM AUTOMATION