

BLEN-3 TRIPLE AXIS BILEVEL STEP MOTOR DRIVER

- 10 Amperes/Phase Maximum Operating Current
- 7 Amperes/Phase Standstill Motor Current
- Transient Voltage Suppression
- Half-Step and Full-Step Operation
- Bilevel Drive Operation
- No RFI or EMI Problems
- TTL/CMOS Compatible Inputs
- Clock and Direction or Dual Clock Operation
- Motor Turn-Off Input

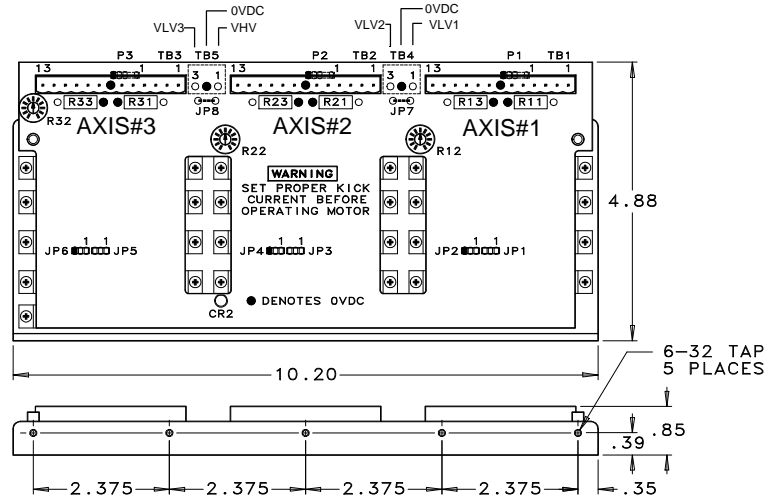

GENERAL DESCRIPTION

The Anaheim Automation BLEN-3 Step Motor Driver is designed to operate six or eight lead, 4-phase step motors rated at 1 - 7 amps/phase. Outstanding motor performance is provided by means of a Bilevel Drive technique.

BILEVEL DRIVE

The basic function of a step motor driver is to control the motor winding currents. Motor performance is determined by how fast the driver can increase and decrease the winding currents. A rapid rise in winding current is achieved by applying a high voltage directly to a motor. This rapid rise of current is also referred to as the "kick" or operating current. When a desired current level is reached, a low voltage is applied to maintain a suitable holding current level. When a motor winding is turned off, a rapid decrease in winding current is achieved by routing the energy in the collapsing field back to the power supply through a high voltage path. The high voltage supply furnishes the energy necessary to maintain motor output torque at high step rates thus providing high mechanical power output. The low voltage supply provides much of

the current needed at low step rates and all of the holding current.

Bilevel drivers do not use high frequency switching techniques as chopper drivers do. Consequently, they do not create the EMI, RFI, and motor heating problems that are associated with chopper drivers.

EXCITATION MODE SELECT

Users have a choice of dual-phase, full-step operation or half-step operation. Dual-phase, full-step operation occurs by energizing two phases at a time, rotating a typical motor 1.8 degrees per step. Half-step operation occurs by alternately energizing one, and then two, phases at a time, rotating the motor 0.9 degrees per step. Full-step operation is only suggested for applications that specifically require that mode, such as when retrofitting existing full-step systems.

STEP AND DIRECTION CONTROL

The BLEN-3 has two clock options: Clock and Direction, or Dual Clock operation. Terminal 5 can be configured as the Direction Input or CCW Input by placing jumper JP1, JP3, and JP5 in the

appropriate position (see Table 1). Pulses applied to the Clock input cause the motor to step in the clockwise direction if the Direction Input is a logic "1" or the counterclockwise direction if the Direction Input is a logic "0". Pulses applied to the CCW Input cause the motor to step in the counterclockwise direction. Either positive or negative going pulse may be selected by setting JP2, JP4, and JP6 to the appropriate position (See Table 1).

MOTOR ON/OFF INPUT

The motor on/off input allows for de-energizing a motor without disturbing the positioning logic. After re-energizing the motor, a routine can continue. This reduces motor heating and conserves power, especially in applications where motors are stopped for long periods and no holding torque is required.

ADJUSTING KICK CURRENT

The kick (or operating) current level is the desired phase current level that the high voltage provides each time a step is taken. The high voltage is turned off when this



ANAHEIM AUTOMATION

910 East Orangefair Lane, Anaheim, CA 92801
e-mail: info@anaheimautomation.com

(714) 992-6990 fax: (714) 992-0471
website: www.anaheimautomation.com

level is reached. The kick current level should be set to approximately 1.4 times the rated phase current. For example, a motor rated at 5 amps/phase should be "kicked" to 7 amps ($5 \times 1.4 = 7$). Table 2 shows various kick current levels for corresponding phase currents. **WARNING:** The kick current level must be set before operating a motor.

TRANSIENT VOLTAGE SUPPRESSION (TVS)

The BLEN-3 contains TVS diodes on the motor phase outputs. The TVS diodes allow longer motor cables to be used. Normally when using long motor cables, voltage transients and spikes are created. These transients often exceed the voltage ratings of the output phase transistors, resulting in blown transistors. The addition of the TVS Diodes suppresses these transients and protects the transistors against damage.

DETERMINING LOW-VOLTAGE SUPPLY LEVEL

The BLEN-3 is capable of having three separate low voltage supplies (one for each axis) or a single low voltage supply for all three axes. It is generally better to use a separate low voltage for each motor, but a single low voltage may be used to simplify the power supply. Jumpers JP7 and JP8 should be clipped out when using separate low voltage supplies for each axis. Jumpers JP7 and JP8 should be soldered in place when using a single low voltage supply. **CAUTION: CHECK JUMPERS JP7 AND JP8 BEFORE APPLYING POWER!**

The Low Voltage supply should provide the motor with 70% to 100% of the rated

motor current. Higher motor current will produce more holding torque. To calculate the Low Voltage (Vlv), use the following equation where Iö is the rated motor current and Rö is the resistance of the motor.

$$V_{lv} = I_{\text{ö}} \times [R_{\text{ö}} + 0.1] + 1.6$$

Example: To operate a motor with ratings of Iö = 4.7 Amps and Rö = 0.39 Ohms, calculate Vlv as follows:

$$V_{lv} = 4.7 (0.39 + 0.1) + 1.6 = 3.9 \text{ Volts}$$

To calculate Vlv for 70% of the rated motor current use the following equation:
 $V_{lv} = 0.7 I_{\text{ö}} \times [R_{\text{ö}} + 0.1] + 1.6$

VERIFYING CORRECT STANDSTILL CURRENT

The final determination of whether adequate standstill current is provided by the Vlv supply may be made as follows:

1. Ground the Mode Select (pin 8) input.
2. Measure the voltage drop across resistors R11, R13 (Axis 1), R21, R23 (Axis 2), and R31, R33 (Axis 3). See Figure 1.
3. Multiplying the reading by 20 gives the standstill current in Amps, which should be between 70 and 100% of rating.
4. Adjust Vlv accordingly. The Vlv can be any voltage equal to the step motors rated volts/phase +2 volts maximum.
5. Disconnect ground from Mode Select Input if driver used is in half-step operation.

DETERMINING HIGH-VOLTAGE SUPPLY LEVEL

The high-voltage supply (Vhv) can range from 24 Vdc to 70 Vdc. The BLEN-3 requires only a single high voltage supply. The Vhv supply determines high-speed torque performance and acceleration. Higher values for Vhv will produce more torque at higher speeds. Lower values for Vhv will result in lower torque at higher speeds.

POWER SUPPLY CONNECTIONS

The Vlv and Vhv power supplies can be connected to the BLEN-3 through the terminal blocks TB1-TB3 on the front of the board, or through TB4 and TB5 (3-pin terminals) on the back of the board.

MOTOR CONNECTIONS

Figure 3 is a typical hookup diagram for BLEN-3 driver applications. *Wiring connected to inputs must be separated from motor connections and all other possible sources of interference.*

IMPORTANT NOTE: When the wiring from the driver to the step motor extends beyond 25 feet, consult the factory.



ANAHEIM AUTOMATION

910 East Orangefair Lane, Anaheim, CA 92801
e-mail: info@anaheimautomation.com

(714) 992-6990 fax: (714) 992-0471
website: www.anaheimautomation.com

SPECIFICATIONS

Control Inputs (All) : (Terminals 5, 6, 8, 9)

TTL-compatible

Logic "0" - 0 to 0.8 V

Logic "1" - 3.5 to 5.0 V

Clock Inputs : (Terminals 5 & 6)

15 microseconds minimum pulse width required. The Clock inputs are internally pulled down to 0Vdc through a 10KΩ resistor for positive going Clock inputs or pulled up to +5Vdc through a 10KΩ resistor for negative going Clock inputs.

Direction Control: (Terminal 5)

pulled up to +5Vdc through a 10KΩ resistor

Logic "1" (open) - CW motor direction

Logic "0" - CCW motor direction

Excitation Mode Select: (Terminal 8)

pulled up to +5Vdc through a 10KΩ resistor

Logic "1" (open) - Half-step

Logic "0" - Full-step

Motor On/Off: (Terminal 9)

pulled up to +5Vdc through a 10KΩ resistor

Logic "1" (open) - motor current on

Logic "0" - motor current off

Output Current Rating:

(Terminals 1, 2, 3, 11, 12, & 13)

10 Amps per phase maximum operating or running current, and 7 Amps per phase maximum standstill current. Motor phase ratings of 1.0 Amp minimum are required to meet the minimum kick level.

Power Requirement :

High Voltage: 24Vdc - 70Vdc

Low Voltage: 3.0Vdc - 7.0 Vdc

Operating Temperature : 0 to 60 degrees C

The BLEN-3 driver should be mounted to a heat conducting structure; fan cooling is also recommended.

FUNCTION	JP1, JP3, JP5	JP2, JP4, JP6
Terminal 5 = Direction	2 - 3	X
Terminal 5 = CCW	1 - 2	X
+ Going Clocks	X	2 - 3
- Going Clocks	X	1 - 2
DEFAULT	2 - 3	1 - 2

TABLE 1: JUMPER SETTINGS

Potentiometer Setting	Rated Motor Current	Kick current
0 - 10	1.0 - 1.4	1.2 - 2.0
10 - 20	1.4 - 2.0	2.0 - 2.8
20 - 30	2.0 - 2.5	2.8 - 3.6
30 - 40	2.5 - 3.1	3.6 - 4.4
40 - 50	3.1 - 3.7	4.4 - 5.2
50 - 60	3.7 - 4.2	5.2 - 5.9
60 - 70	4.2 - 4.8	5.9 - 6.7
70 - 80	4.8 - 5.4	6.7 - 7.5
80 - 90	5.4 - 5.9	7.5 - 8.3
90 - 100	5.9 - 7.0	8.3 - 10.0

TABLE 2: KICK CURRENT SETTINGS

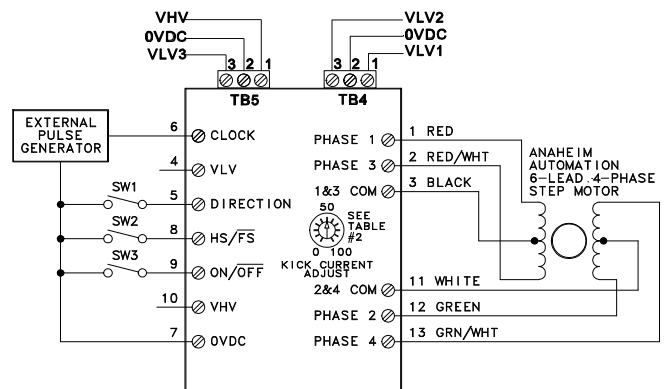

FIGURE 3: HOOKUP DIAGRAM.



ANAHEIM AUTOMATION

910 East Orangefair Lane, Anaheim, CA 92801

e-mail: info@anaheimautomation.com

(714) 992-6990 fax: (714) 992-0471

website: www.anaheimautomation.com

TORQUE/SPEED CURVES

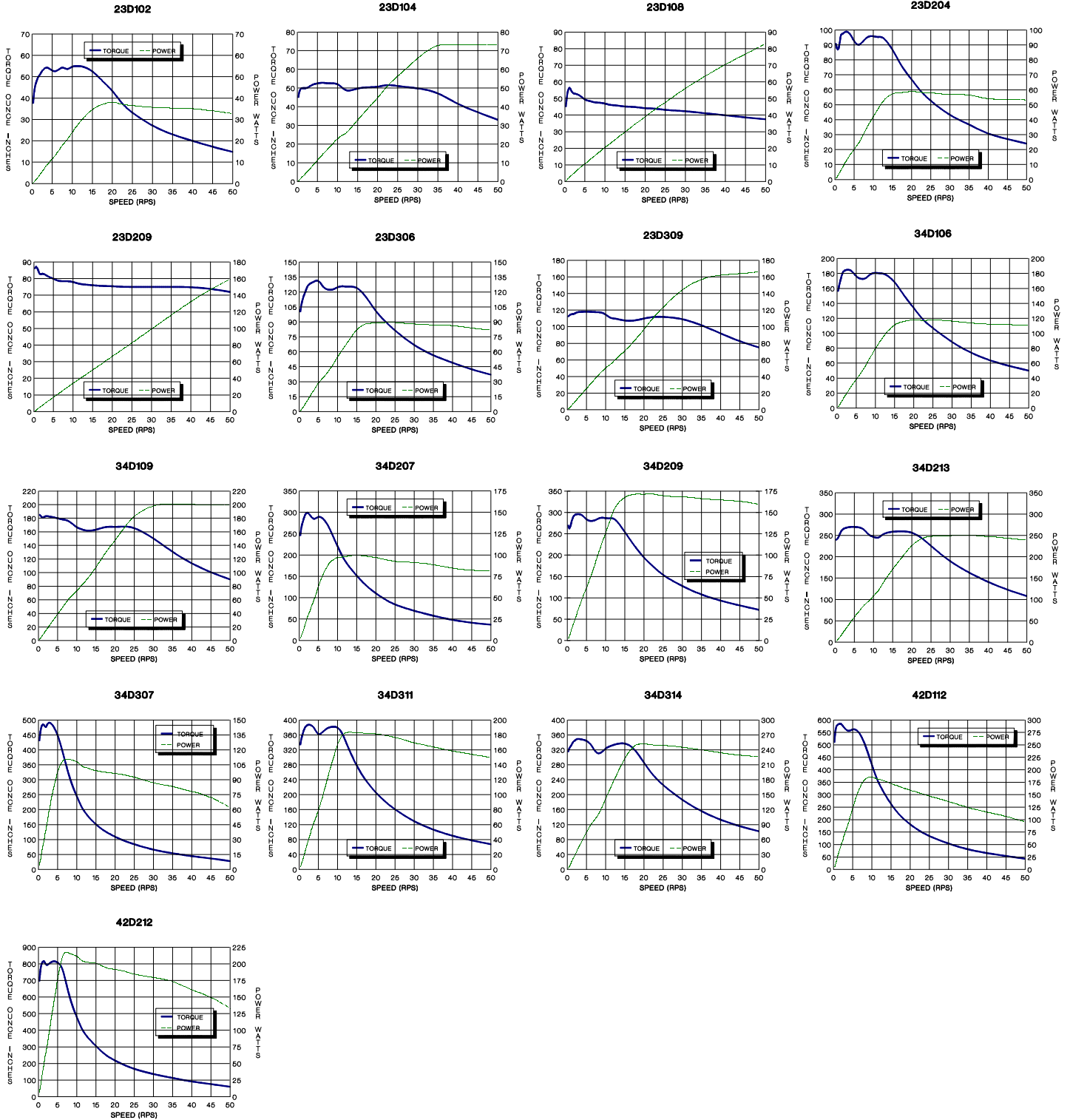

ANAHEIM AUTOMATION

910 East Orangefair Lane, Anaheim, CA 92801
 e-mail: info@anaheimautomation.com

(714) 992-6990 fax: (714) 992-0471
 website: www.anaheimautomation.com