

MBB45021-75 Enhanced Step Motor Driver

User's Guide



A N A H E I M A U T O M A T I O N

910 East Orangefair Lane, Anaheim, CA 92801
e-mail: info@anaheimautomation.com

(714) 992-6990 fax: (714) 992-0471
website: www.anaheimautomation.com

MBB45021-75 Enhanced Driver Features

- 1.0-4.5 Amperes/Phase Operating Current
- Enhanced Torque/Speed Output
- Improved Start-Stop Speeds
- Short Circuit Protection
- Open Motor Wire Detection
- No RFI or EMI Problems
- Requires 17-28 VAC or 24-40 VDC
- TTL-CMOS Compatible Inputs
- Receives Positive or Negative Going Clocks
- Full Step or Half Step Operation
- Motor Turn Off Provisions
- Enclosed Modular Package

General Description

The Anaheim Automation MBB45021-75 is a bilevel step motor driver packaged with an integral power supply and is specifically designed to dynamically enhance driver performance while circumventing the effects of input voltage variations. The stratagem of this design is to use regulation techniques to effect a continuous productive change in response to motor operating conditions and input voltage variations.

Bilevel Drive

The basic function of a step motor driver is to control the motor winding currents. Motor performance is determined by how fast the driver can increase and decrease the winding currents. A rapid rise in winding current is achieved by applying a high voltage directly to a motor winding. This rapid rise of current is also referred to as the “kick” or operating current. When a desired current level is reached, the high voltage is turned off and a low voltage is applied to maintain a suitable holding current level. When a motor winding is turned off, a rapid decrease in winding current is achieved by routing the energy in the collapsing field back to the power supply through a high voltage path. The high voltage supply furnishes the energy necessary to maintain motor output torque at high step rates thus providing high mechanical power output. The low voltage supply provides much of the current needed at low step rates and all of the holding current. Bilevel drivers do not use high frequency switching techniques as chopper drivers do. Consequently, they do not create the EMI, RFI, and motor heating problems that are associated with chopper drivers.

Half Step/Full Step

Users have a choice of full-step or half-step operation. Full-step operation occurs by energizing two phases at a time, rotating a typical motor 1.8 degrees per step. Half-step operation occurs by alternately energizing one, and then two, phases at a time, rotating the motor 0.9 degrees per step. Full-step operation is only for applications that specifically require that mode, such as when retrofitting existing full-step systems. JP3 is used to change between half step and full step operation. Please see the section on Jumper Functions/ Locations for placement of this jumper.

Motor On/Off - Reset

The Motor On/Off feature allows the de-energizing of a motor without disturbing the positioning logic. After re-energizing the motor, a routine can continue. This reduces motor heating and conserves power, especially in applications where motors are stopped for long periods. The reset pin is used to reset a fault condition. This input must be held low for at least 10 msec to reset the driver.

Clock Modes

The MBB45021-75 has two clock options: clock and direction, or dual clock operation. Jumper JP2 is used to select the clock option. Basically JP2 selects TB1 pin 2 as either the direction input or the CCW input.

With the clock and direction option (most common option), clock pulses applied to the clock input cause the motor to step. The direction of the motor is determined by the logic level of the direction input. Jumper JP2 must be in the "2-3" position for this mode. Physical direction also depends on the motor wiring.

With the dual clock option, clock pulses applied to the clock input cause the motor to step in the clockwise direction. Clock pulses applied to the CCW input cause the motor to step in the counter-clockwise direction. Jumper JP2 must be in the "1-2" position for this mode.

Either positive or negative going pulses may be used by setting jumper JP1 in the appropriate position. To determine which setting to use, first consider the type of clock pulse output on the pulse generator or indexer (controller). If the clock output on the controller is open-collector type (sinking), then use the negative going jumper setting (position "1-2"). If the clock output on the controller is a pnp or p-channel (sourcing) type, then use the positive going jumper setting (position "2-3"). If the clock output on the controller is a TTL/CMOS type (totem pole), then either setting will work; but the jumper setting should be chosen based on the level of the clock output when the controller is not pulsing. If the clock is low when not pulsing, then use positive going jumper settings. If the clock is high when not pulsing, then use the negative going jumper setting.

Motor Connection

Refer to the hookup diagram for typical driver applications. Wiring connected to inputs must be separated from motor connections and all other possible sources of interference. **Important Note:** When the wiring from the driver to the step motor extends beyond 25 feet, consult the factory.

Current Adjust Setting (CUR. ADJ.)

The potentiometer R7 is used to set the motor current. The pot should be set according to the motor's rated current. This will produce a kick current of 1.4 times the rated motor current.

Pot Setting	Rated Motor Current	Kick Current
0%	.80A	1.10A
10%	1.15A	1.60A
20%	1.55A	2.15A
30%	1.90A	2.65A
40%	2.25A	3.20A
50%	2.65A	3.70A
60%	3.00A	4.20A
70%	3.40A	4.75A
80%	3.75A	5.25A
90%	4.15A	5.80A
100%	4.50A	6.30A

Low Voltage Adjust (VLV ADJ.)

The potentiometer R26 is used to set the motor low voltage (VLV) supply which furnishes the current necessary for holding (standstill) torque and low-speed running torque. Higher values for the low voltage will produce more holding and low-speed torque. A proper VLV will produce a standstill current that is 65 to 100% of the rated motor current (i.e. for a motor rated at 1 Amp, VLV should be set so that the standstill current is 0.65 to 1 Amps).

Motor	Standstill Current (Amps/Phase)	VLV ADJ. Pot Setting	Motor	Standstill Current (Amps/Phase)	VLV ADJ. Pot Setting
17L002_*-LW8	.7	0%	23L306_*-LW8	2.1	55%
17L102_*-LW8	.7	45%	23D102_*	.7	45%
17L202_*-LW8	.7	55%	23D104_*	1.4	20%
17L203_*-LW8	1.05	20%	23D204_*	1.26	35%
23L002_*-LW8	.7	45%	23D306_*	2.03	30%
23L102_*-LW8	.7	80%	34D106_*	2.1	20%
23L104_*-LW8	1.4	20%	34N104_*-LW8	1.4	65%
23L106_*-LW8	2.1	0%	34N108_*-LW8	2.73	30%
23L204_*-LW8	1.4	35%	34K104_*-LW8	1.4	65%
23L206_*-LW8	2.1	30%	34K108_*-LW8	2.73	30%
23L303_*-LW8	1.05	35%	x	x	x

* Substitute S or D for Single or Dual Shaft Motor

Jumper Functions/ Locations

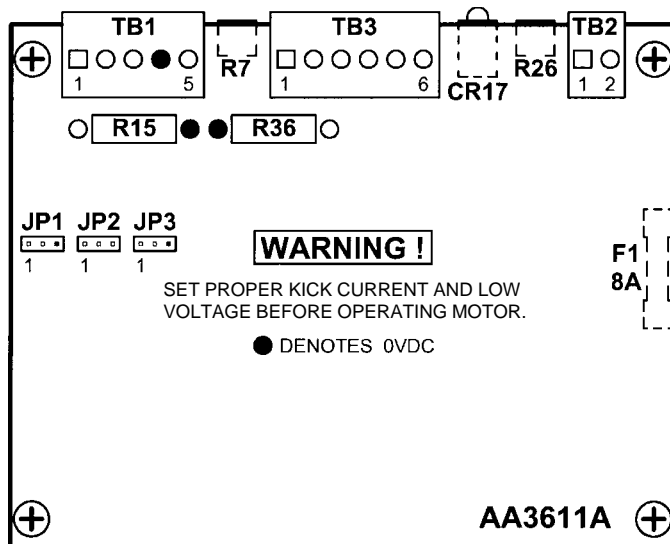

Function	JP1	JP2	JP3
Negative Going Clock Input	1-2	X	X
Positive Going Clock Input	2-3	X	X
TB1 Pin 2 = CCW	X	1-2	X
TB1 Pin 2 = Direction	X	2-3	X
Half Step Operation	X	X	1-2
Full Step Operation	X	X	2-3
Standard Product (Ready to Ship)	1-2	2-3	1-2

Wiring Diagram

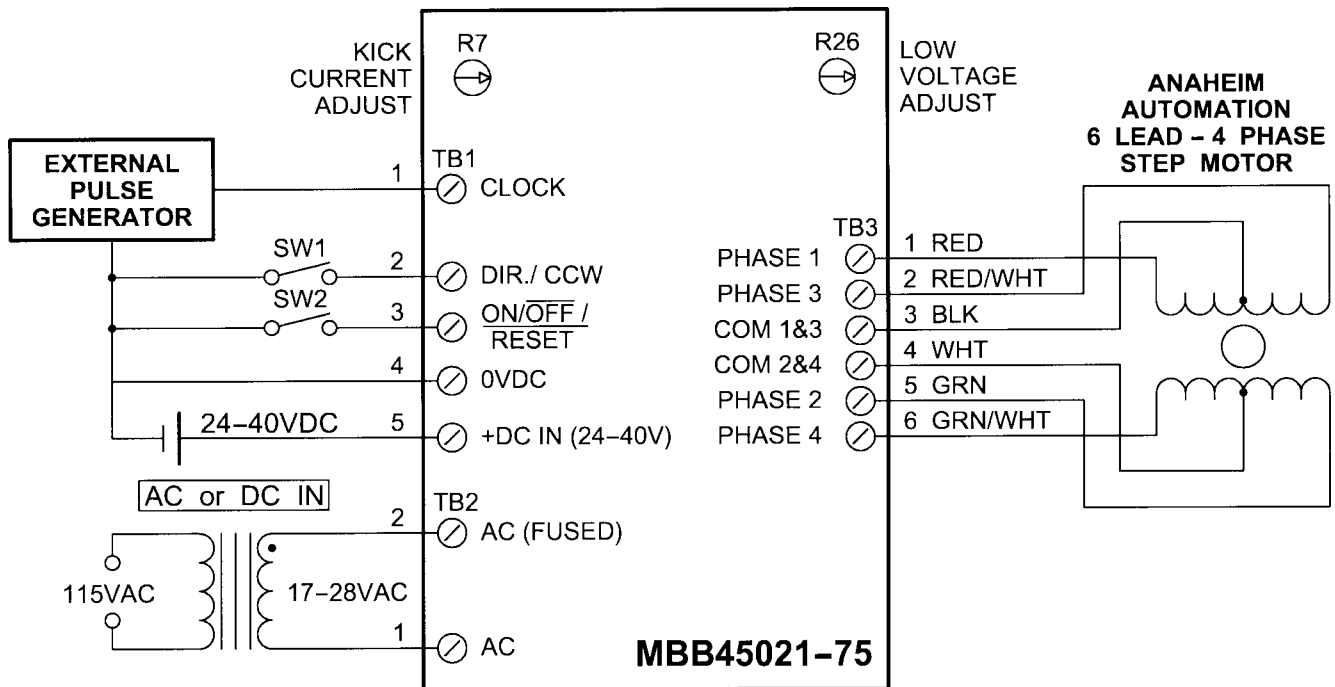

Heating Considerations

The temperature of the heatsink should never be allowed to rise above 60 degrees Celsius. If necessary, air should be blown across the heatsink to maintain suitable temperatures.

Power Requirements

The MBB45021-75 can be powered by an AC or DC voltage (see specifications). For AC operation, the driver may be purchased with a recommended step down transformer. A single transformer may be used to power up several drivers based on power consumption.

Terminal Descriptions

TB1

Pin	Description
1	Clock Input
2	Directional Control
3	Motor On/Off - Reset
4	0VDC
5	(+24-40V) DC Power Input (Fused)

TB2

Pin	Description
1	(17-28VAC) Power Input
2	(17-28VAC) Power Input (Fused)

TB3

Pin	Description
1	Phase 1
2	Phase 3
3	Com 1 & 3
4	Com 2 & 4
5	Phase 2
6	Phase 4

Dimensions

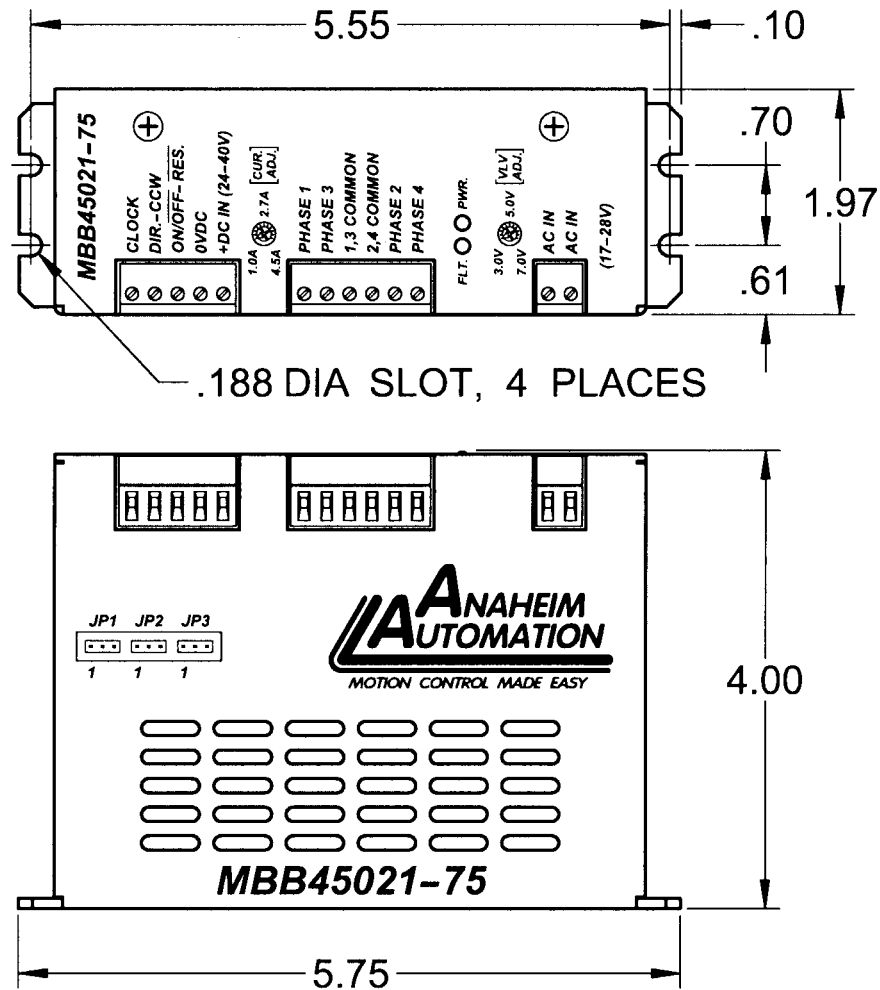

Fault Protection

There are 3 types of fault detection. When a fault is detected, the driver turns off the motor current and the dual LED indicates which type of fault occurred. The upper LED is green during normal operation.

Lower LED Red	Shorted wire in the motor or cable.
Lower LED Green	Open wire in the motor or cable.
Upper LED Red	Excessive power consumption.

If the driver goes into a fault condition, the fault may be reset by turning the power off for at least 20 seconds or by pulling the reset input (TB1 pin 3) to a logic "0" for at least 10 msec.

Transformer Drawings

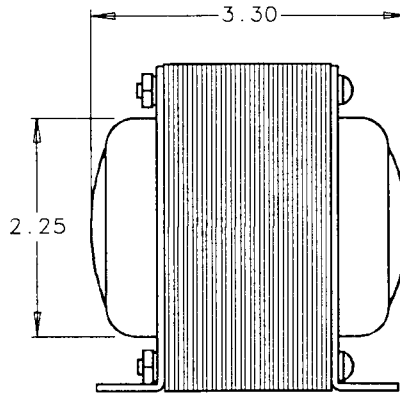
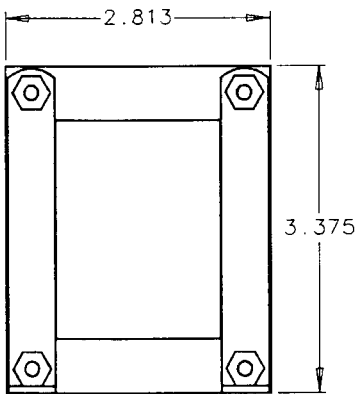
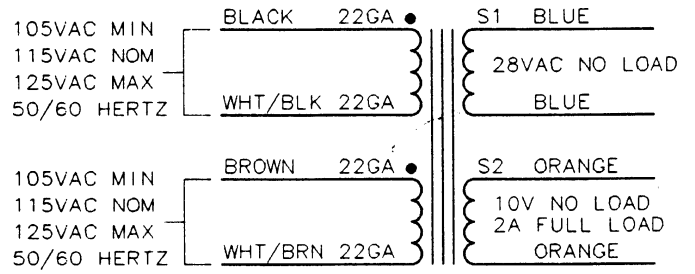
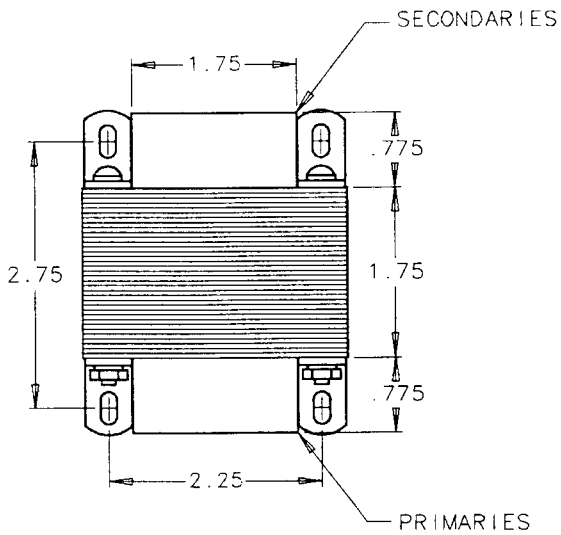

Transformer Wiring Diagrams

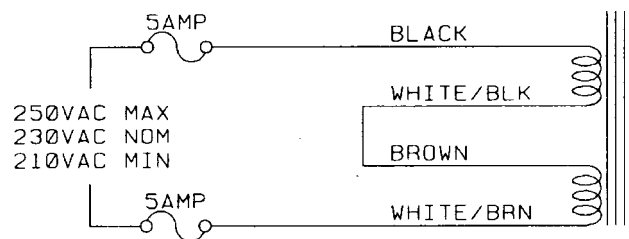
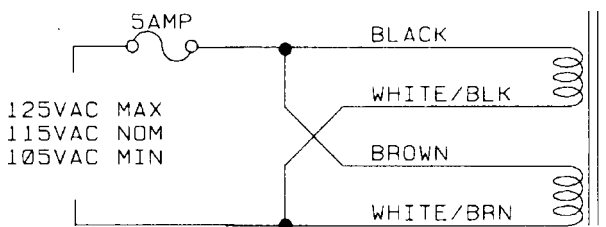

Specifications

Control Inputs:

TTL-CMOS Compatible

Logic "0"=0 to 0.8 VDC

Logic "1"=3.5 to 5.0 VDC

Terminals 1 and 2 on TB1 are pulled up or down (depending on jumpers) through 10k ohm resistors.

Terminal on TB1 is pulled up through a 10k ohm resistor.

Clock, CCW:

(Terminals 1 and 2 of TB1)

15 microseconds minimum pulse width, positive or negative going.

Direction Control:

Logic "1" (open)-clockwise

Logic "0"-counterclockwise

Motor On/Off:

Logic "1" (open)-motor energized

Logic "0"-motor de-energized

Output Current Rating:

5.0 Amperes per phase maximum operating current; 2.5 Amperes per phase maximum standstill current, over the operating voltage and temperature range. Motor phase ratings of 0.8 Amperes minimum are required to meet the minimum kick level.

Power Requirements:

17 VAC (min)-28 VAC (max) or

24 VDC (min)-40 VDC (max)

Operating Temperature:

Heatsink - 0° to 60°C

Fuse:

8 Amp Fast Blow, 5 x 20mm

Power Supply Ordering Information

DC Supply	AC Transformer
PSA40V4A	AA2295
PSA24V2.7A	AA2784
PSA40V8A	AA2785

The AA2784 is the recommended transformer. For additional info on other transformers please contact the factory.

Troubleshooting

If a fault occurs, reset the fault by applying a logic “0” to the reset input (TB1 pin 3) for at least 10 msec (or by cycling power OFF for at least 20 seconds). After resetting, try to run the motor again. If the driver faults again then check the conditions listed below.

Is the lower LED red?

This indicates that the motor has a phase shorted or there is a short in the motor cable or wiring. Check the motor and the wiring for shorts. If the driver continues to sense “shorts” after the motor and wiring are determined to be accurate, then the output transistor should be checked (see below).

Is the lower LED green?

This indicates that there is an open or intermittent connection in one of the motor wires. Check the motor and the wiring for opens. Another condition that may cause this type of fault, is when a large motor is ramped down too quickly so that it loses its positioning.

Is the upper LED red?

This indicates that the motor/driver application is consuming excessive power. This detection turns off power to the motor, protecting the driver’s circuitry. An application exceeding 160 watts is not intended for the MBB45021-75. Another condition that may cause this type of fault, is when the input voltage is too low. A higher rated DC supply or AC transformer may solve this problem (see power supply ordering information).

Checking Output Transistors

1. Remove the cover plate.
2. Set the multimeter to “diode test”.
3. Place the red meter lead on (between) the sense resistors (labeled as R15 and R36 in Jumper Functions/Locations).
4. Touch the black meter lead to each phase (TB3 pins 1,2,5 and 6).
5. Readings should be between 0.450 VDC and 0.550 VDC.
6. If any readings are significantly less than 0.450 VDC, then the unit has been damaged.

If a factory repair is required, please contact Anaheim Automation for an RMA# at

(800) 345-9401 or (714) 922-6990

Torque Speed Curves

MBB45021-75 with 17L102

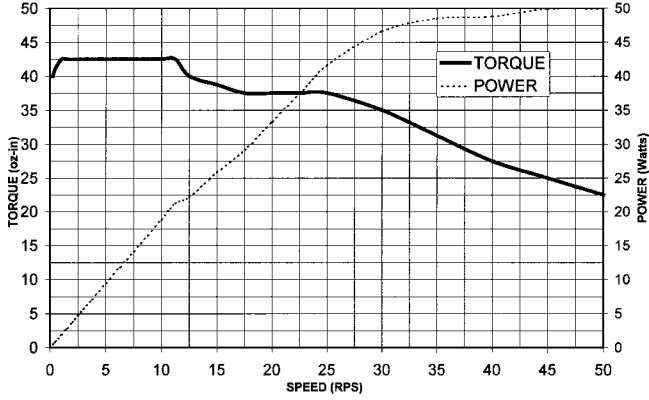

MBB45021-75 with 17L203

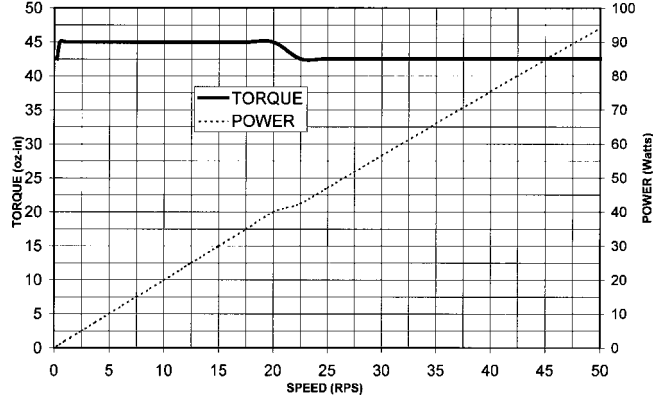

MBB45021-75 with 23L104

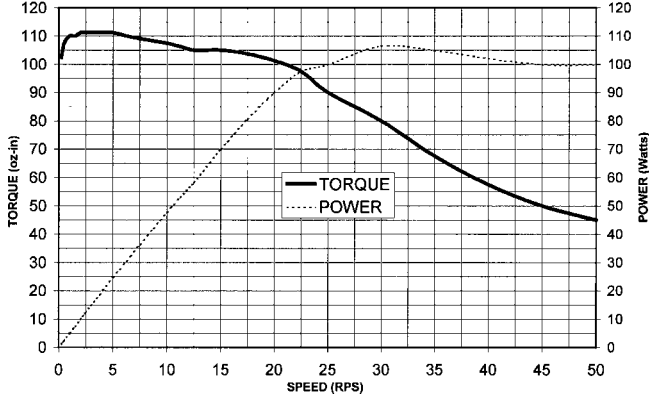

MBB45021-75 with 23L206

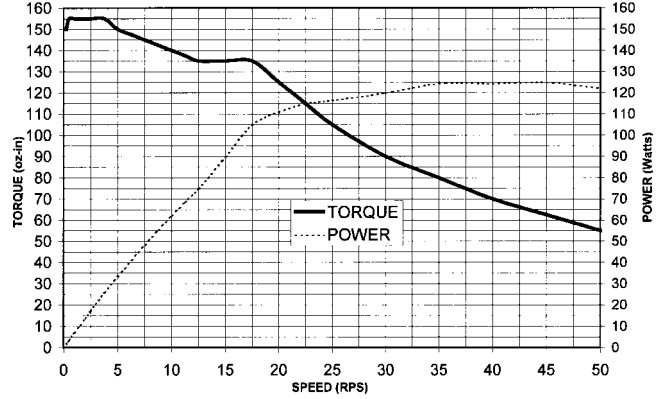

MBB45021-75 with 23L306

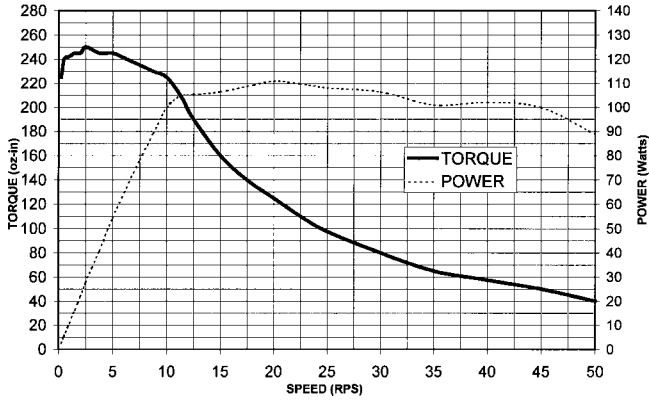

MBB45021-75 with 34N108

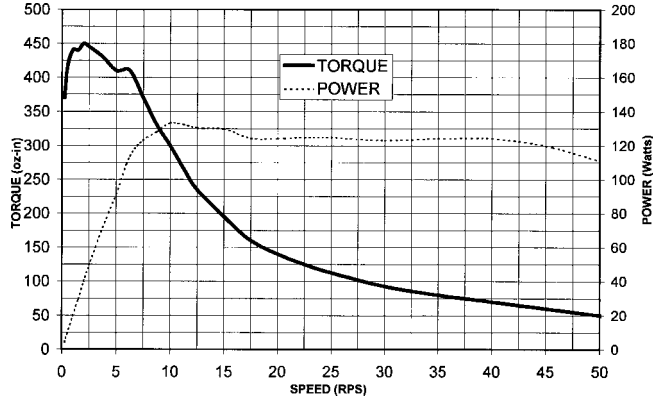

COPYRIGHT

Copyright 2001 by Anaheim Automation. All rights reserved. No part of this publication may be reproduced, transmitted, transcribed, stored in a retrieval system, or translated into any language, in any form or by any means, electronic, mechanical, magnetic, optical, chemical, manual, or otherwise, without the prior written permission of Anaheim Automation, 910 E. Orangefair Lane, Anaheim, CA 92801.

DISCLAIMER

Though every effort has been made to supply complete and accurate information in this manual, the contents are subject to change without notice or obligation to inform the buyer. **In no event will Anaheim Automation be liable for direct, indirect, special, incidental, or consequential damages arising out of the use or inability to use the product or documentation.**

Anaheim Automation's general policy does not recommend the use of its' products in life support applications wherein a failure or malfunction of the product may directly threaten life or injury. Per Anaheim Automation's Terms and Conditions, the user of Anaheim Automation products in life support applications assumes all risks of such use and indemnifies Anaheim Automation against all damages.

LIMITED WARRANTY

All Anaheim Automation products are warranted against defects in workmanship, materials and construction, when used under Normal Operating Conditions and when used in accordance with specifications. This warranty shall be in effect for a period of twelve months from the date of purchase or eighteen months from the date of manufacture, whichever comes first. **Warranty provisions may be voided if products are subjected to physical modifications, damage, abuse, or misuse.**

Anaheim Automation will repair or replace at its' option, any product which has been found to be defective and is within the warranty period, provided that the item is shipped freight prepaid, with previous authorization (RMA#) to Anaheim Automation's plant in Anaheim, California.

TECHNICAL SUPPORT

If you should require technical support or if you have problems using any of the equipment covered by this manual, please read the manual completely to see if it will answer the questions you have. If you need assistance beyond what this manual can provide, contact your Local Distributor where you purchased the unit, or contact the factory direct.

ANAHEIM AUTOMATION