

MBC25P11 Programmable Pulse Generator/ Driver

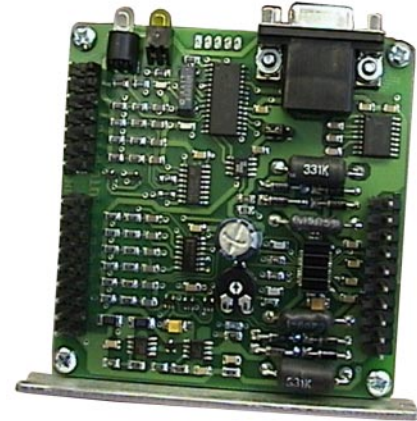

FEATURES

- Output Current of 2.5A Peak
- 200 to 1600 Steps/Revolution (1, 2, 4 and 8 Selectable Step Operation)
- Drives Two Motors In Series
- On-Board Programmable Pulse Generator
- Pulses From 77Hz to 15kHz
- Directional Soft and Hard Limit Switch Inputs
- Clock Output for Daisy Chaining
- Busy Output
- Motor On/Off Input and Automatic Current Reduction
- Short Circuit Protection



DESCRIPTION

General Description

The MBC25P11 is an economical single axis step motor driver integrated with a programmable pulse generator. The MBC25P11 microstep driver/pulse generator has an output current capability of 0.5A minimum to 2.5A maximum (peak rating). The MBC25P11 driver operates with a DC voltage of 12VDC to 35VDC. The MBC25P11's internal PG (pulse generator) has four different programmable motion profiles. The MBC25P11 also has directional soft and hard limit switch inputs, a busy output and a clock output that can be used for daisy chaining drivers together. The MBC25P11 driver features direction control and motor current On/Off capabilities. The "Reduce Current Enabled" feature automatically reduces motor current to 70% of the set value. The driver has built in features to indicate power on (green LED), running implemented. These divisions range from 200 steps/rev to 1600 steps/rev. The bipolar drive configuration handles 4, 6, and 8 lead step motors and is also equipped with short circuit, over temperature and crossover current protection. The MBC25P11 communicates via RS232 communication. The easy to use Windows software, SMPG10WIN, is used to directly set up to four different motion profiles.

DIMENSIONS

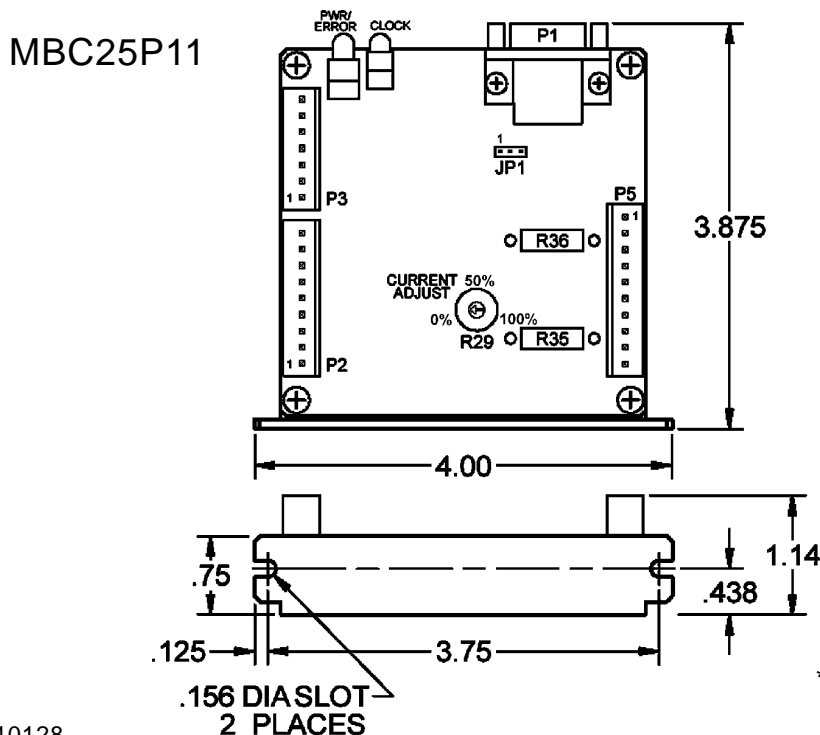

*All units are in inches

L010128

One Motor Hookup

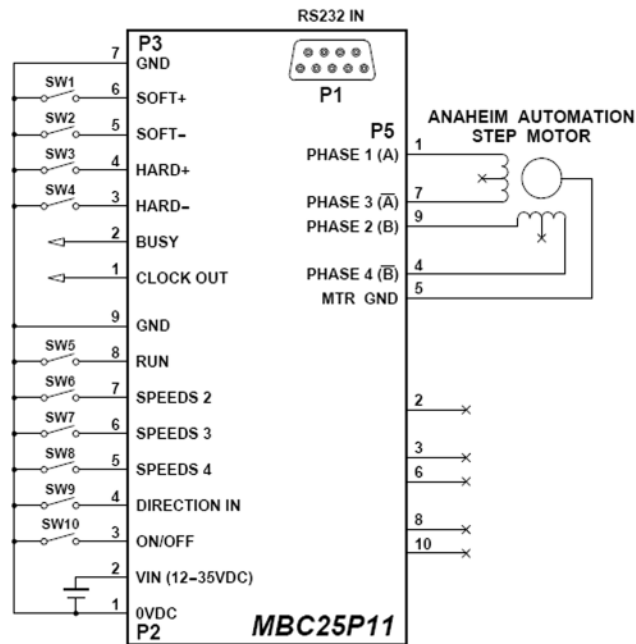

Specifications

Power Requirments:	12 - 35VDC
Output Current Range:	$T_A = 25^\circ\text{C}$ 0.5 - 2.5A Peak
Clock Out Frequency: (P3, Pin 1)	77Hz - 15kHz
Driver Chopping Frequency	25kHz - 30kHz
Operating Temperature:	0° C to 70° C

Ordering Information

Model #	Description
MBC25P11	2.5A Microstep Driver with Integrated Programmable Pulse Generator
PSAM24V2.7A	Power supply for MBC25P11 (24V@2.7A)
CON-6404287	Optional 7 pin connector, 0.156" IDC (AMP part no. 640428-7)
CON-6404289	Optional 9 pin connector, 0.156" IDC (AMP part no. 640428-9)
CON-16404280	Optional 10 pin connector, 0.156" IDC (AMP part no. 1-640428-0)
AA9MFC-6	6 foot serial communication cable, Male to Female