

34A Series - Linear Actuator Stepper Motors

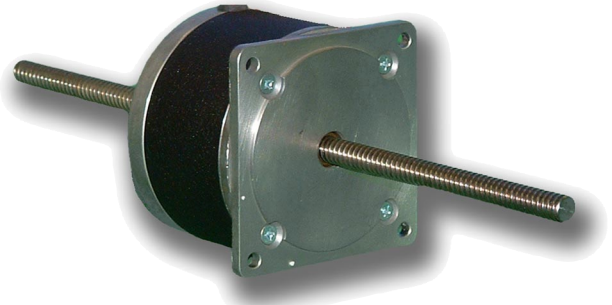

FEATURES

- **Step Motor with Internal Conversion to Linear Output**
- **Self Contained Package with Long Shielded Ball Bearings**
- **Available in a Wide Variety of Voltage and Inductance Ratings**
- **Can be Microstepped for Smoothness and Resolutions up to 2×10^{-5} inches**
- **Several Lead Screw Choices**



DESCRIPTION

The 34A Series stepper motor offers many advantages to users over previous design choices. All of the lower cost digital attributes of a hybrid step motor are retained while the internal conversion to linear motion eliminates the need for other rotary- to-linear conversions such as belt and pulleys, racks and pinions, or external ball screws. Motion designs can be simplified, production costs lowered and product life enhanced. The 34A design captures a bronze acme nut internally such that each normal electrical step sequence results in the linear travel of a mating screw axially. Since the ends of the screw are free-floating, any length can be used; if the motor is fixed, the screw will travel, if the screw is fixed, the motor will travel. Normal open loop drivers can be used. Typical applications for the linear step motor actuator include X-Y tables, pick and place, medical instrumentation, valve adjustment, and test equipment. We can bring together many of the components required to make your application work the best.

SPECIFICATIONS

Model #	NEMA Size	Maximum Force (lbs)	Series Current (A)	Unipolar Current (A)	Unipolar Resistance (ohms)	Unipolar Inductance (mH)	Rotor Inertia (oz-in-sec ²)	Travel per Step (Inch)*	# of Lead Wires	Weight (lbs)	L Length (in)
34A106B	34	198	2.1	3.0	0.95	3.20	0.009	0.0003125	6	3.35	2.54
34A106D	34	124	2.1	3.0	0.95	3.20	0.009	0.0005000	6	3.35	2.54
34A106E	34	62	2.1	3.0	0.95	3.20	0.009	0.0010000	6	3.35	2.54
34A109B	34	198	3.4	4.8	0.39	1.20	0.009	0.0003125	6	3.35	2.54
34A109D	34	124	3.4	4.8	0.39	1.20	0.009	0.0005000	6	3.35	2.54
34A109E	34	62	3.4	4.8	0.39	1.20	0.009	0.0010000	6	3.35	2.54

* Suffix B has 0.0625 inch lead screw
 Suffix D has 0.100 inch lead screw
 Suffix E has 0.200 inch lead screw

- Internal rotating nut: SAE 660 Bearing Bronze
- 3/8" Dia. Acme Leadscrew: 300 Series Stainless Steel
- Recommended Lubrication: White Lithium Grease

L010366

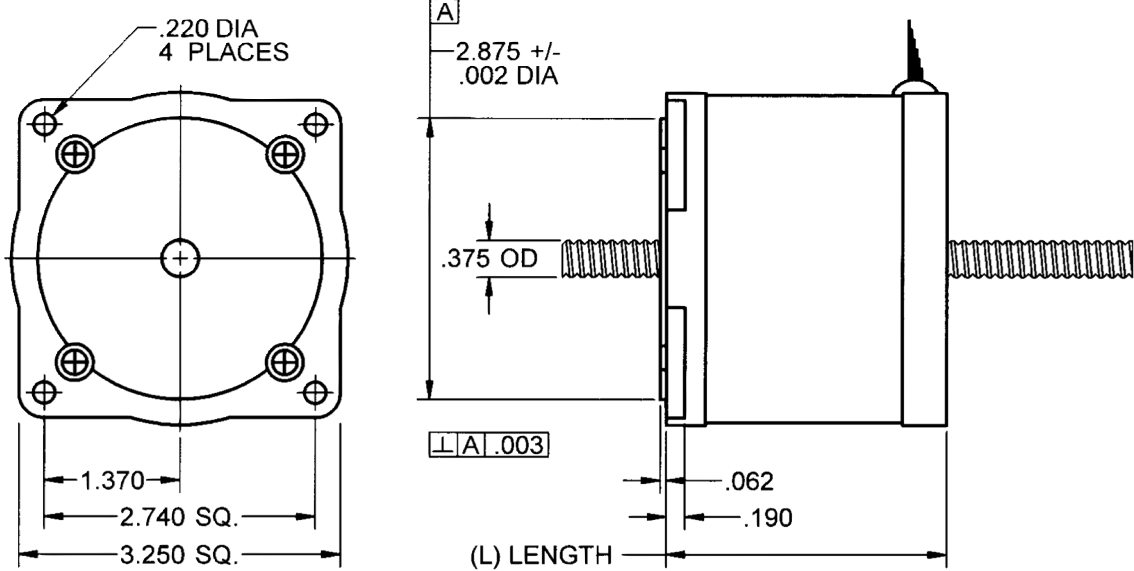

Note: All leadscrews require lubrication periodically. (All units are inches)

DIMENSIONS

Connection	Lead Wire Connection	Lead Wire Color
4 - Lead Bipolar Series MBC or MLP Series	Phase 1 (A)	Red
	Phase 3 (/A)	Red/White
	Phase 2 (B)	Green
	Phase 4 (/B)	Green/White
	Tie Off	Black
6 - Lead Unipolar BLD, TM Series	Phase 1	Red
	Phase 3	Red/White
	Phase 2	Green
	Phase 4	Green/White
	Common Phase 1 & 3	Black
	Common Phase 2 & 4	White

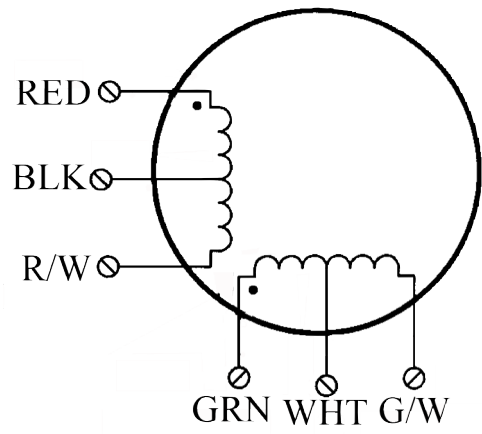

WIRING INFORMATION

Step Angle Accuracy:	+/- 5% (Full Step, No Lead)
Resistance Accuracy:	+/- 10%
Inductance Accuracy:	+/-20%
Temperature Rise:	80° C Max (2 Phases On)
Ambient Temperature:	-20° to + 50° C
Insulation Type:	Class B

SPECIFICATIONS