

42Y65 Series - IP65 Sealed High Torque Stepper Motors - Splash Proof

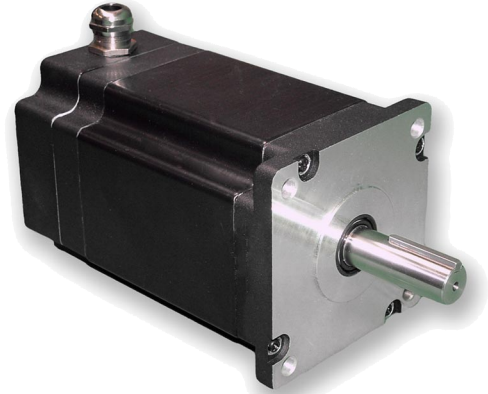

FEATURES

- **NEMA 42 Frame Size**
- **1.8° Step Angle**
- **High Torque - Up to 4036 oz-in**
- **Sealed per IP65 Standard for Splashproof**
- **High Step Accuracy and Resolution**
- **Low Vibration and Noise**
- **Can be Customized for**
 - Winding Current
 - Shaft Option
 - Cables and Connectors
- **CE Certified and RoHS Compliant**



DESCRIPTION

The 42Y65 Series High Torque Stepper Motors are designed to withstand splashdown, humid or damp environments, and water sprayback conditions. The IP65 sealed properties ensure that moisture be kept out of the motors internal electronics. In addition, these motors provide the highest possible torque available in a sealed size 42 stepper. The 42Y65 series is an excellent choice for lab automation, biotech, and semiconductor automation equipment, just to name a few. Customized options are also available upon request.

See Accessories on our website for optional motor adders such as encoders, brakes, cables and connectors. For gearbox options, see our GBPH Series gearboxes. For compatible drivers, consider our popular MBC082561, MBC10641, MBC12101 and MLA10641 drivers, and Driver packs,

SPECIFICATIONS

Model #	NEMA Size	Bipolar Torque (oz-in)	Series Current (A)	Unipolar Current (A)	Parallel Current (A)	Unipolar Inductance (mH)	Rotor Inertia (oz-in-sec ²)	Shaft Diameter (in)	# of Terminals	Weight (lbs)	L Length (in)
42Y65112S-CB8	42	1700	4.25	6.0	8.5	2.9	0.102	0.75	8	13.5	4.5
42Y65212S-CB8	42	2974	4.25	6.0	8.5	10.5	0.154	0.75	8	18.5	5.9
42Y65312S-CB8	42	4036	4.25	6.0	8.5	12.0	0.229	0.75	8	26.0	7.9

Notes: Custom cables, connectors, and windings are available upon request.

L010397

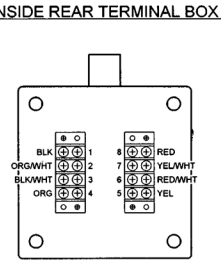
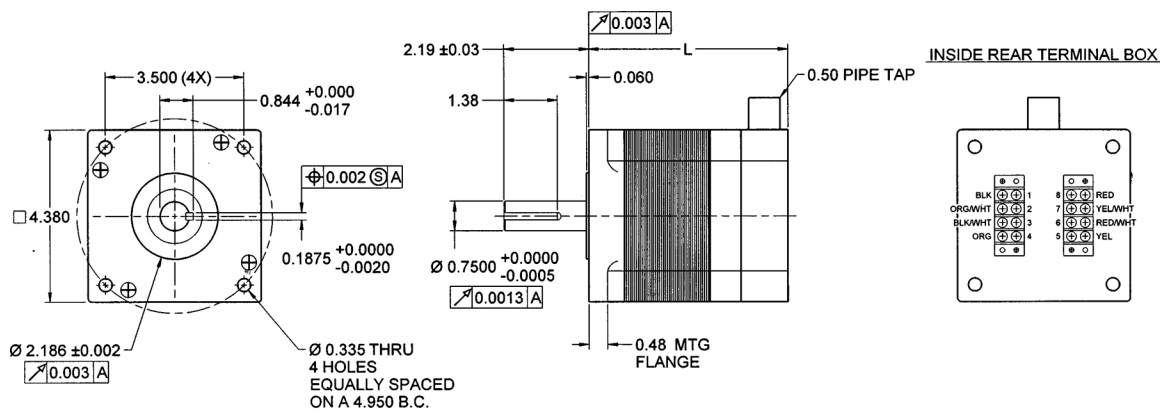

(All units are inches)

Connection	Lead Wire Connection	Lead Wire Color	Terminal #
4 - Lead Bipolar Series MBC or MLP Series	A	Black	1
	/A	Orange	4
	B	Red	8
	/B	Yellow	5
	None	White/Black & White/Orange	2 & 3
4 - Lead Bipolar Parallel MBC or MLP Series	A	Black & White/Orange	1 & 2
	/A	Orange & White/Black	3 & 4
	B	Red & White/Yellow	7 & 8
	/B	Yellow & White/Red	5 & 6
	None	White/Red & White/Yellow	6 & 7
6 - Lead Unipolar BLD, TM Series	Phase 1	Black	1
	Phase 3	Orange	4
	Phase 2	Red	8
	Phase 4	Yellow	5
	Common Phase 1 & 3	White/Black & White/Orange	2 & 3
	Common Phase 2 & 4	White/Red & White/Yellow	6 & 7

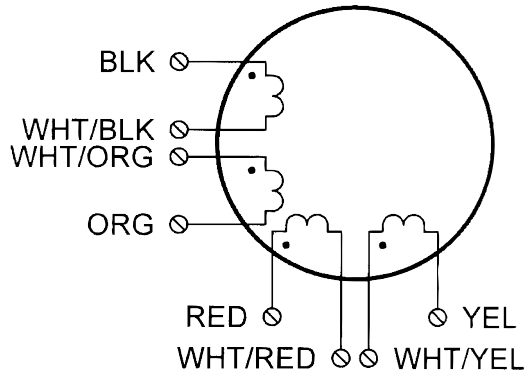

Step Angle Accuracy:	+/- 5% (Full Step, No Load)	Insulation Resistance:	100M Ohm Min, 500VDC
Resistance Accuracy:	+/- 10%	Dielectric Strength:	1800VAC/s for 5mA
Inductance Accuracy:	+/- 20%	Shaft Radial Play:	0.02" Max (1.0 lb load)
Temperature Rise:	80° C Max (2 Phases On)	Shaft Axial Play:	0.08" Max (1.0 lb load)
Ambient Temperature:	-20° to +50° C	Max Radial Force:	49.5 lbs (0.79" from flange)
Insulation Type:	Class B	Max Axial Force:	13.5 lbs-Force