

# MBDC050-024031-120V 110VAC Input Brush DC Controller

## User's Guide



**ANAHEIM AUTOMATION**

4985 East Landon Drive, Anaheim, CA 92807  
e-mail: [info@anaheimautomation.com](mailto:info@anaheimautomation.com)

(714) 992-6990 fax: (714) 992-0471  
website: [www.anaheimautomation.com](http://www.anaheimautomation.com)

## MBDC050-024031-120V Driver Features

- **Fixed Current Limit Set at 3.0 Amps with an output power up to 35W**
- **0.5V to 5V External Voltage Speed Control**
- **2-Quadrant Operation**
- **Open-Loop Velocity Mode**
- **24VDC Motor Bus**
- **Requires 85-135 VAC Input**
- **Freewheel and Direction Inputs**
- **Cycle by Cycle Short Circuit Protection**
- **Compact Size (4.73" X 3.19" X 1.54")**
- **Screw Type Terminal Block**

### General Description

The MBDC050-024031-120V driver is designed to drive DC brush motors at peak currents of up to 3.0A and 35W. The MBDC050-024031-120V is a compact, low profile package meant to be used where space is limited but performance is expected and eliminates the need for an external power supply. The MBDC050-024031-120V driver is designed to drive DC brush motors at peak currents of up to 3.0A and 36W. The driver has a motor bus voltage of 24V. An external potentiometer (10K) or external voltage (0.5-5VDC) can be used to control the speed. The direction of the motor can be preset by the direction control input. To disable energy from the motor, there is a Freewheel input that can be enabled by allowing current through the input opto-diode.

### Pin Descriptions

The inputs on the MBDC050-024031-120V are optically isolated. For the Direction and Freewheel opto-diodes the anode (+) and cathode (-) where both are brought to the user. An analog voltage to control the speed is also optically isolated. With no current going through the Direction, Freewheel opto-diodes, the input is considered high. To enable the motor to Run, current must not go through the Freewheel input opto-diode and an analog voltage from 0.5V to 5V must be applied to VSPD. To Freewheel (remove energy from the motor) the motor, current must go through the Freewheel input opto-diode. To preset the direction of the motor, current must not go through the Direction input opto-diode (clockwise) or current must go through the Direction input opto-diode (counter clockwise). The Direction and Freewheel inputs are compatible from 3.5V to 24V.

### Optically Isolated Inputs and Output

The following inputs and output to the MDC200-024051 are Optically Isolated:

Item	Pin #
ISO 5VOUT	1
ISO GND	3
Direction	4 & 5
Freewheel	6 & 7
VSPD*	2

\*VSPD: 0.5 - 5V analog signal referenced to ISO GND.

## Absolute Maximum Ratings

Vspeed Control: (TB1, Pin 2):	0VDC - Motor Stopped 5VDC - Max Speed (6VDC max)
Control Inputs (TB1, Pins 4-7):	3.5VDC - 24VDC 1mA minimum
Direction Control: (TB1, Pins 4 & 5)	Logic "1" (open) - Clockwise Logic "0" - Counterclockwise
Freewheel: (TB1, Pins 6 & 7)	Logic "1" (open) - Motor is Enabled Logic "0" - Motor is de-energized and will coast
ISO5VOUT Output: (TB1, Pin 1)	5.1V @ 50mA Maximum
Power Requirements: (TB3, Pins 1 & 2)	85VAC (min) - 132VAC (max)
Motor Voltage Bus:	24VDC
Motor Output Current:	3.0A peak (1.5A average) maximum operating current.
Operating Temperature:	0°C to 70°C

## Heating Considerations

The temperature of the heat sink should never be allowed to rise above 70° Celsius. If necessary, mount the unit to an additional heat sink or air should be blown across the heat sink to maintain suitable temperatures.

## Terminal Pin Out

Pin #	Description
1	ISO 5VOUT
2	VSPD
3	ISO GND
4	Direction +
5	Direction -
6	Freewheel +
7	Freewheel -

TB1: Opto-isolated Control Inputs, Outputs and Speed Control

Pin #	Description
1	OUT 1
2	OUT 2

TB2: Motor Phase Terminals

Pin #	Description
1	AC Hot
2	AC Neutral
3	EARTH GND (must be connected)

TB3: AC Voltage In Terminals

## Terminal Descriptions

### Motor Freewheel

The motor freewheel feature allows the de-energizing of the motor phases. A low at this input causes the motor to coast to a stop, while a high (open) input causes the motor to run at the given speed.

### Motor Direction

The motor direction feature allows the changing of the rotation of the motor. This input should not be changed while motion is in progress. A low at this input causes the motor to turn in the CW direction, while a high (open) input causes the motor to turn in the CCW direction.

### Speed Adjust, ISO 5V, and ISO GND

To adjust the motor speed, the external voltage input can be varied from 0.5V to 5V. An external potentiometer can be connected from ISO 5VOUT supply to ISO GND, with the wiper attached to VSPD.

### Fault Protection

If a fault occurs, the internal fault protection is activated and shutting off the motor output. If the fault remains after 1.2mS, the motor output shutoff will repeat. The fault conditons are:

1. Over Current. The driver is equipped with cycle-by-cycle current limiting at 3A.
2. Over Temperature on driver IC exceeding 120°C.
3. Under-voltage Lockout activation at 6.5VDC for the motor bus caused by shorted AC input.

## Dimensions

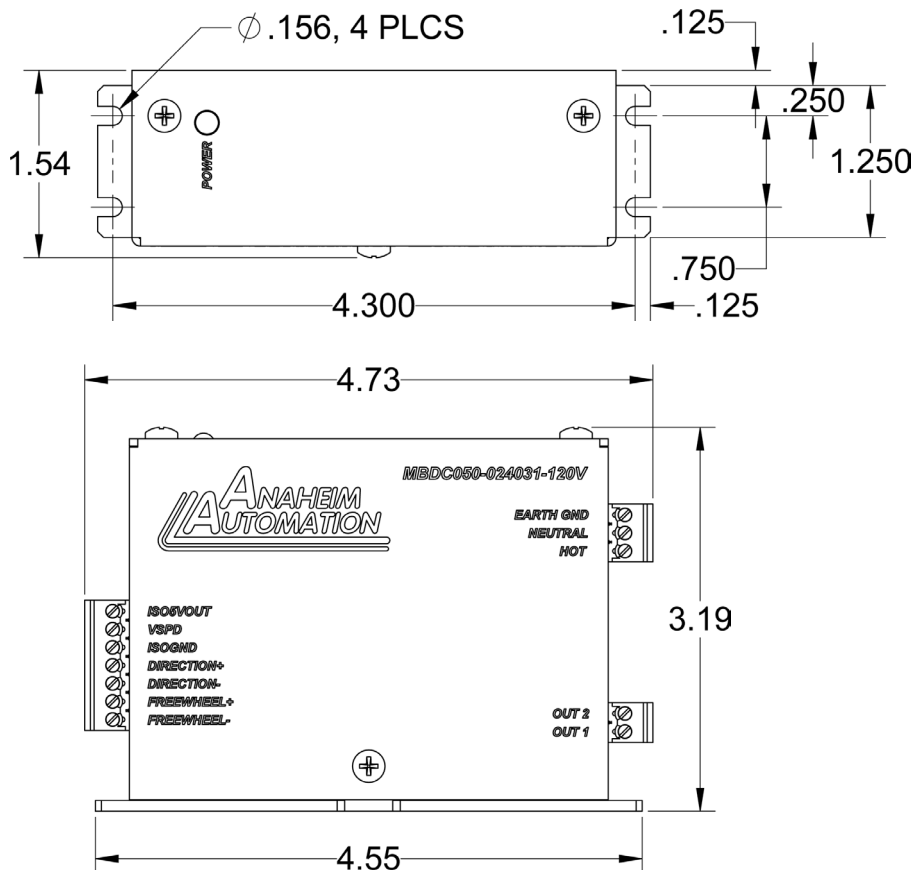

# Typical Wiring Diagram

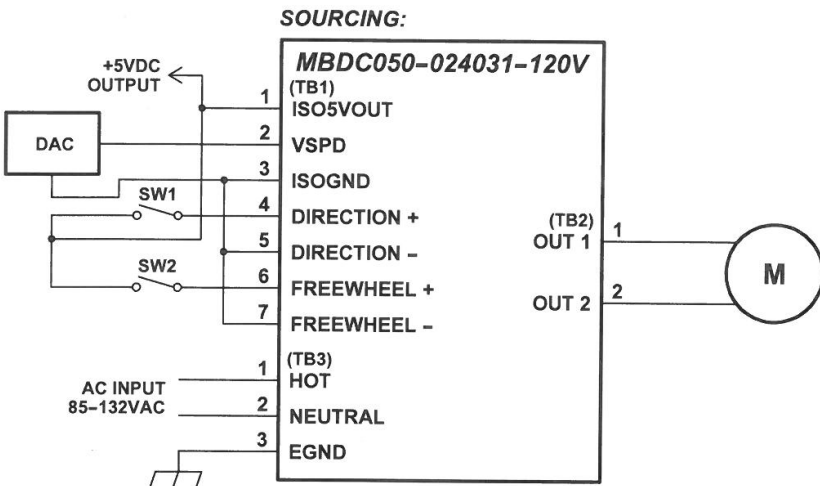
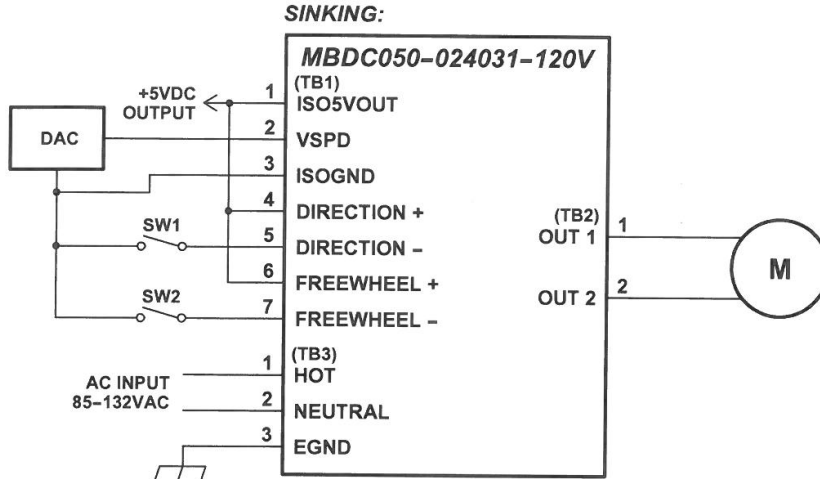

# Torque Curves

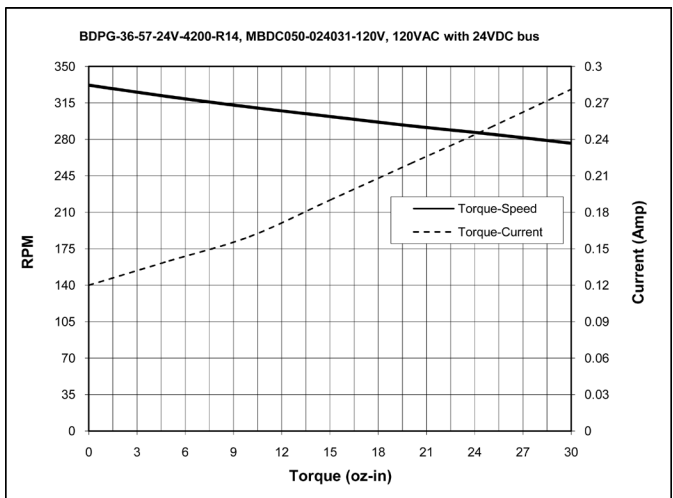
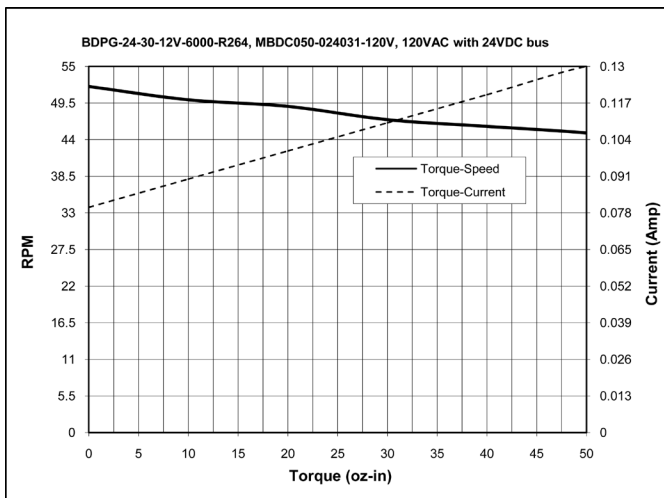

## **COPYRIGHT**

Copyright 2014 by Anaheim Automation. All rights reserved. No part of this publication may be reproduced, transmitted, transcribed, stored in a retrieval system, or translated into any language, in any form or by any means, electronic, mechanical, magnetic, optical, chemical, manual, or otherwise, without the prior written permission of Anaheim Automation, 4985 E Landon Drive, Anaheim, CA 92807.

## **DISCLAIMER**

Though every effort has been made to supply complete and accurate information in this manual, the contents are subject to change without notice or obligation to inform the buyer. **In no event will Anaheim Automation be liable for direct, indirect, special, incidental, or consequential damages arising out of the use or inability to use the product or documentation.**

Anaheim Automation's general policy does not recommend the use of its' products in life support applications wherein a failure or malfunction of the product may directly threaten life or injury. Per Anaheim Automation's Terms and Conditions, the user of Anaheim Automation products in life support applications assumes all risks of such use and indemnifies Anaheim Automation against all damages.

## **LIMITED WARRANTY**

All Anaheim Automation products are warranted against defects in workmanship, materials and construction, when used under Normal Operating Conditions and when used in accordance with specifications. This warranty shall be in effect for a period of twelve months from the date of purchase or eighteen months from the date of manufacture, whichever comes first. **Warranty provisions may be voided if products are subjected to physical modifications, damage, abuse, or misuse.**

Anaheim Automation will repair or replace at its' option, any product which has been found to be defective and is within the warranty period, provided that the item is shipped freight prepaid, with previous authorization (RMA#) to Anaheim Automation's plant in Anaheim, California.

## **TECHNICAL SUPPORT**

If you should require technical support or if you have problems using any of the equipment covered by this manual, please read the manual completely to see if it will answer the questions you have. If you need assistance beyond what this manual can provide, contact your Local Distributor where you purchased the unit, or contact the factory direct.

**ANAHEIM AUTOMATION**