

MDC200-024051 - Brushless DC Controller



FEATURES

- Fixed Current Limit Setting at 5 Amps Up to 50W Power Output
- External Speed Control
- Run/Stop, Freewheel and Direction Inputs
- 24VDC Motor Voltage Bus
- 2-Quadrant Operation
- Hall Sensor Feedback
- Constant Velocity Mode
- Requires 85-135 VAC Power Input
- Dual Mounting Option
- RoHS Compliant



DESCRIPTION

The MDC200-024051 driver is a velocity control driver designed to drive DC Brushless Motors from a supply of 120VAC. The driver has a motor bus voltage of 24V, a fixed phase current of 5A and power output of 50W. Using hall sensor feedback, a constant velocity mode is present. The driver is protected against over current (cycle-by-cycle), hall sensor error and under voltage. When an error occurs, a fault light is turned on to notify the user. When an over current occurs the driver will shutoff. An isolated 5V input is needed to power the user inputs. A 0.5 - 5V analog signal is needed to control the speed of the motor.

Ideal Applications

Automated machinery or processes that involve food, cosmetic, or medical packaging, labeling, or tamper-evident requirements, cut-to-length applications, electronic assembly, robotics, factory automation, special filming and projection effects, medical diagnostics, inspection and security devices, conveyor and material handling systems, metal fabrication (CNC machinery), pump flow control, XY and rotary tables, equipment upgrades or wherever precise positioning or speed control is required.

WIRING DIAGRAM

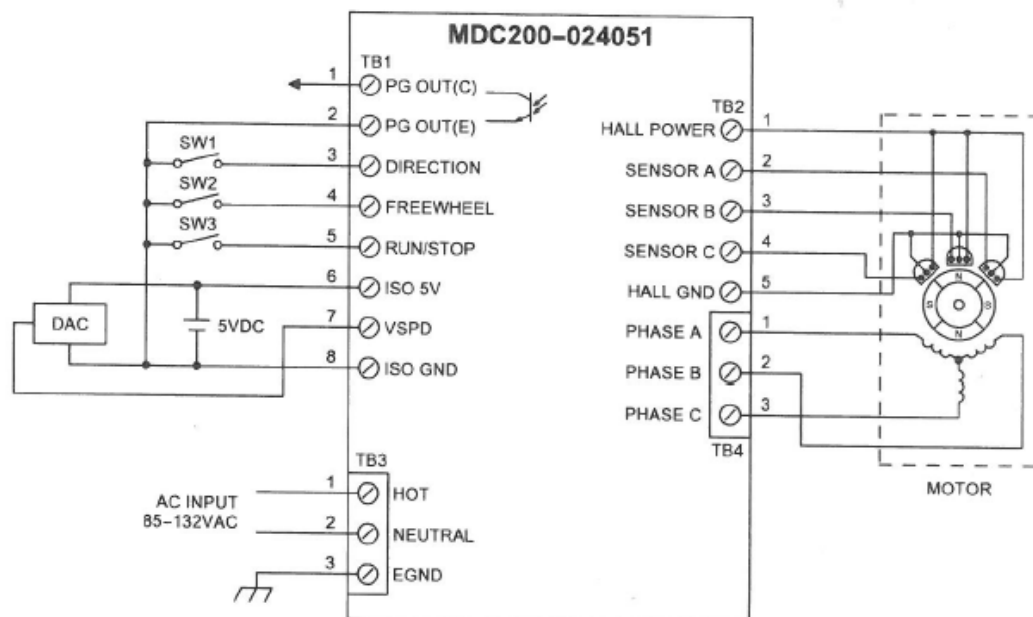

L011167

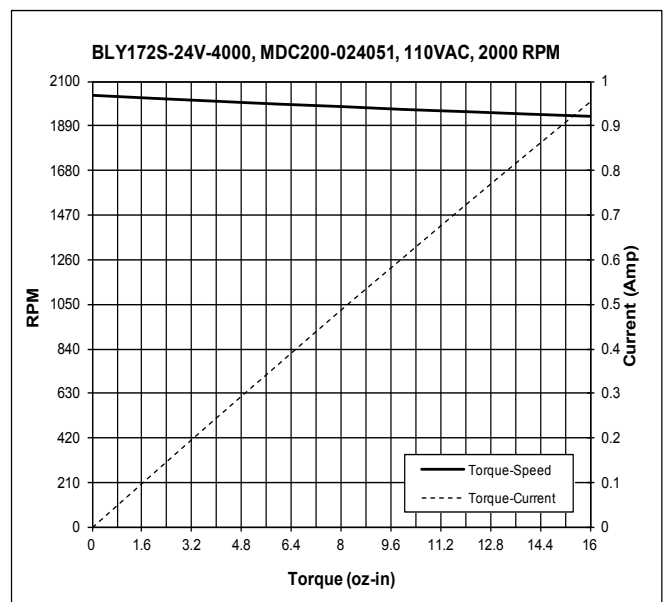
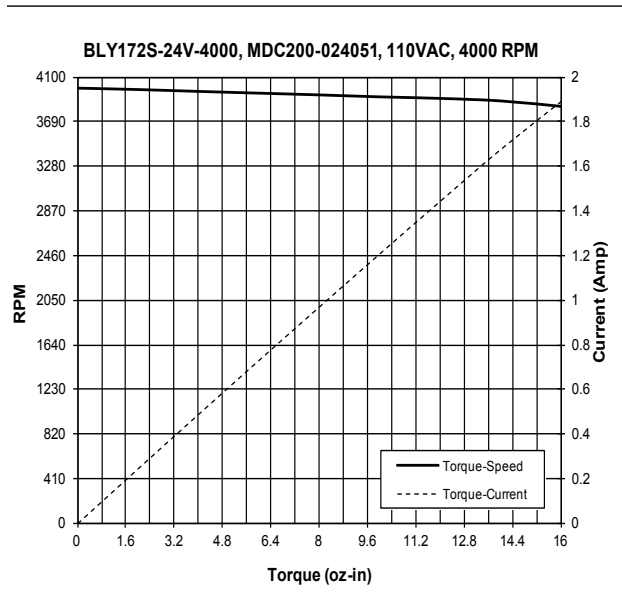
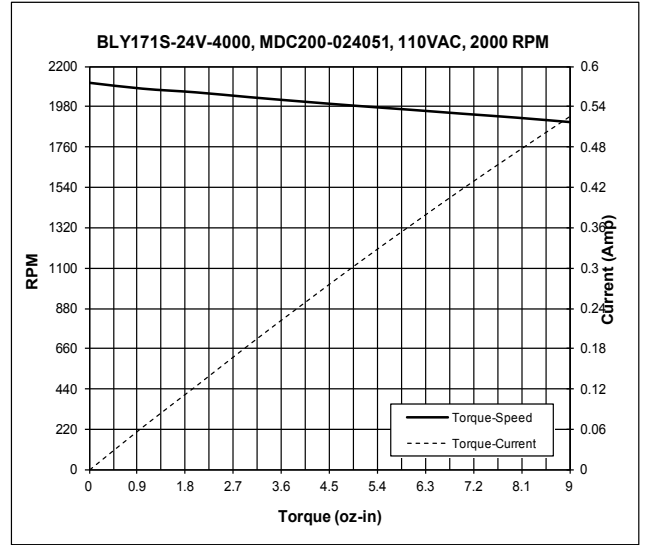
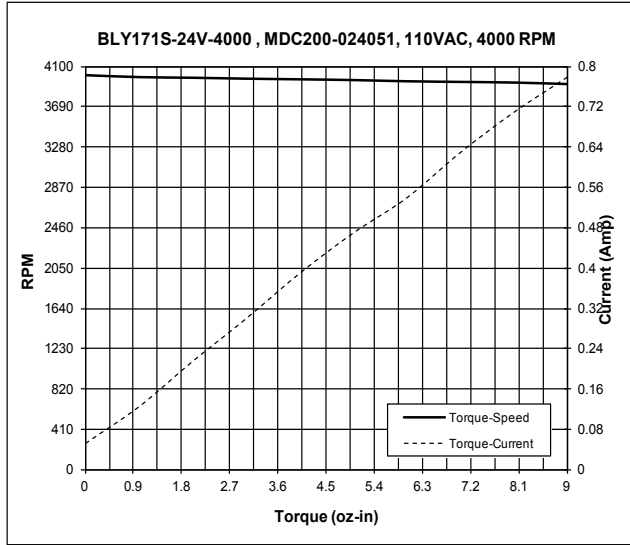

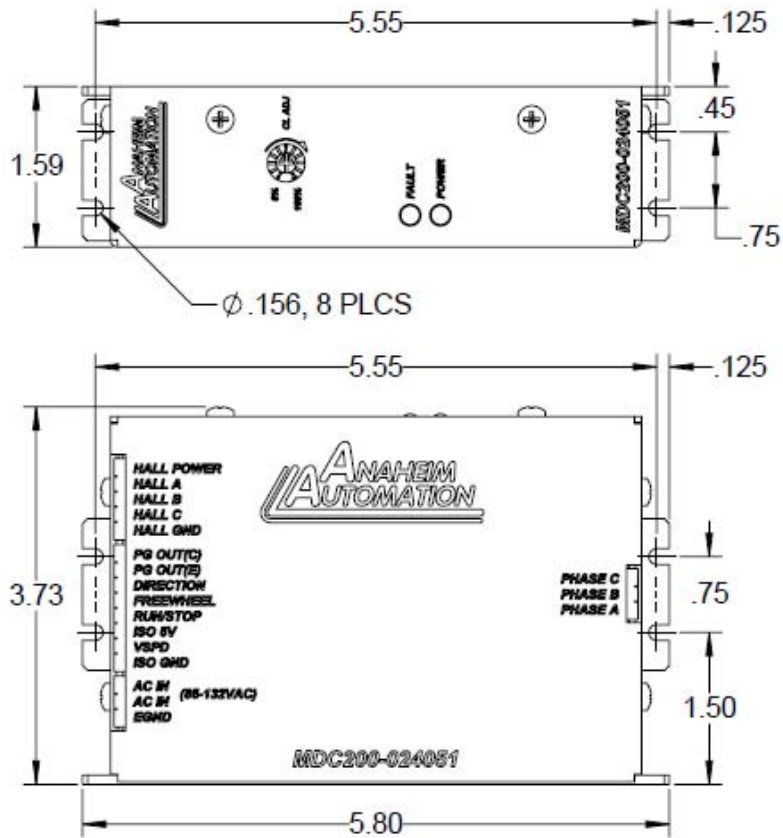

Power Requirements: (TB3, Pins 1 and 2) 85VAC(min) - 135VAC (max)

Output Current Range: 1.0 - 5.0 Amps (Peak)
0.5 - 2.5 Amps (Continuous)

Operating Temperature: Heat Sink 0° - 70°C

Hall Sensor Power Input @ ISO 5V: (5V @ 30mA maximum. Typical current draw from hall sensors is 20mA. All three Hall Sensor inputs are pulled up through 10K ohm resistors.

Closed Loop: (Constant Velocity Mode) The driver is intended for Closed Loop applications. The Closed Loop adjustments are needed for faster and slower motor operation, within the restrictions of the motor rated speed. The adjustments provide a direct duty cycle to the driver with respect to the required motor speed. To obtain the necessary changes, the jumper will vary between pins 1, 2, and 3. Also, by adjusting the trimming pot CL ADJ.