

ENC-EC35 Optical Commutation Encoder

FEATURES

- Differential Outputs for A/B/Z Channels
- U/V/W Commutation Outputs (Differential or Open-Collector)
- Operating Temperature of -20° to +105° C
- 500 to 60,000 Cycles Per Revolution (CPR)
- 2,000 to 40,000 Pulses per Revolution
- Powered From a Single +5VDC Power Supply
- Accepts ± .005" Axial Shaft Play
- Frequency Response from DC up to 1 MHz
- Compatible with .197" to .394" Shaft Size Diameters
- RoHS Compliant



DESCRIPTION

The ENC-EC35 is an optical commutation encoder designed for OEM motion control applications. The ENC-EC35 requires a minimum shaft length of .500" and suitable for shaft sizes ranging from .197" to .394" in diameter. This series encoder provides differential outputs for A/B/Z Channels and U/V/W brushless motor commutation. A differential or open-collector output option is available for U/V/W brushless motor commutation. However, single-ended output can be obtained from the ENC-EC35 by using the (+) output for each differential pair. The internal line drivers of this encoder series can either source or sink 20mA at TTL levels. To achieve maximum noise immunity, the differential receiver can be terminated with a 110 ohm resistor in series with at .0047 uF capacitor placed across each differential pair. The ENC-EC35 is powered from a single +5VDC power supply and is equipped with a 15-pin connector. Applications making use of hall sensor output on brushless motors for position and speed control can eliminate shifting errors by aligning the U/V/W commutation output of the encoder and the output phases of the motor.

ORDERING INFORMATION

ENC-EC35 - 01000 - 4 - 375 - H - D - D

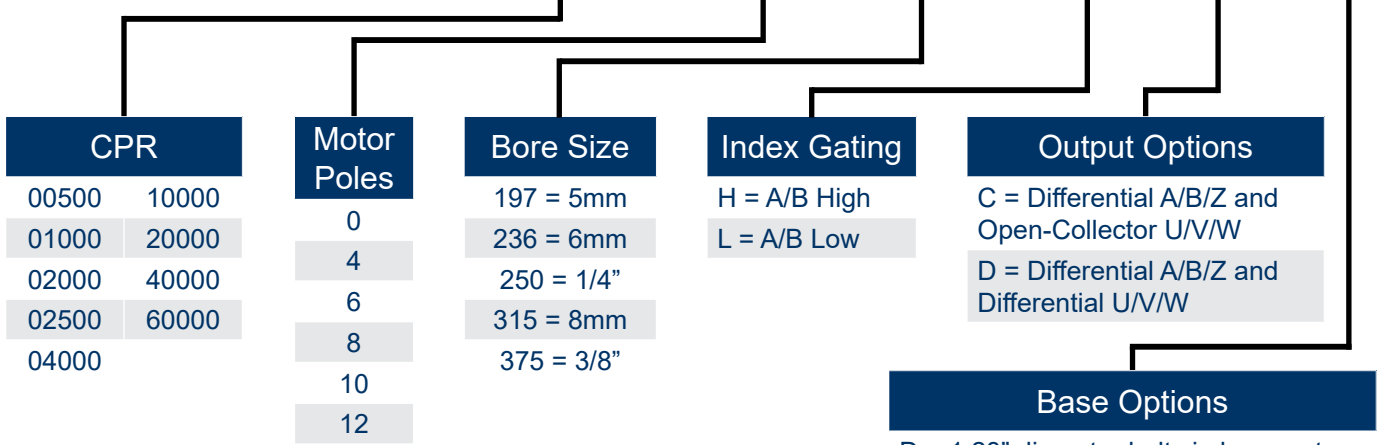

Note: Output must be equal to D when motor poles is equal to 0.

- ### Base Options
- D = 1.28" diameter bolt circle mount, #2-56 x 3/16 screws (qty. 2)
 - DM = 1.28" diameter bolt circle mount, M2.5x5 screws (qty. 2)
 - G = 1.812" diameter bolt circle mount, #4-40 x 3/16 screws (qty. 2)
 - GM = 1.812" diameter bolt circle mount, M2.5x5 screws (qty.2)

L010856

D and DM Option:

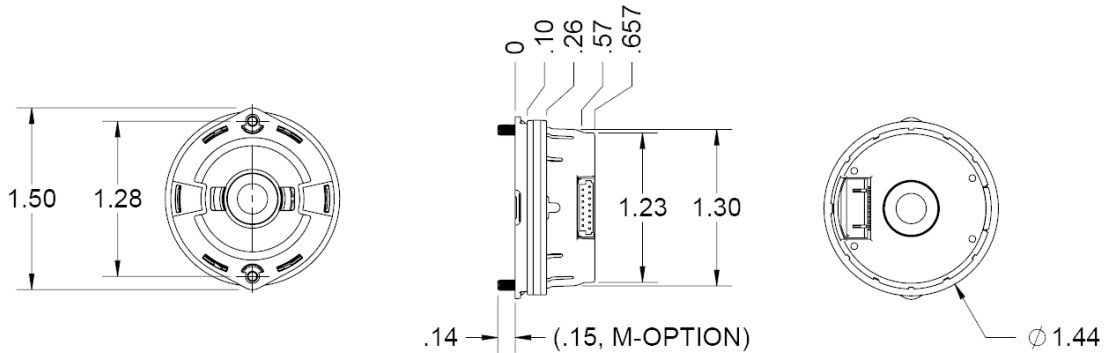

#2-56 x 3/16 SCREWS
QTY 2 SUPPLIED
(M-OPTION SUBSTITUTE M2.5 x 5)

G and GM Option:

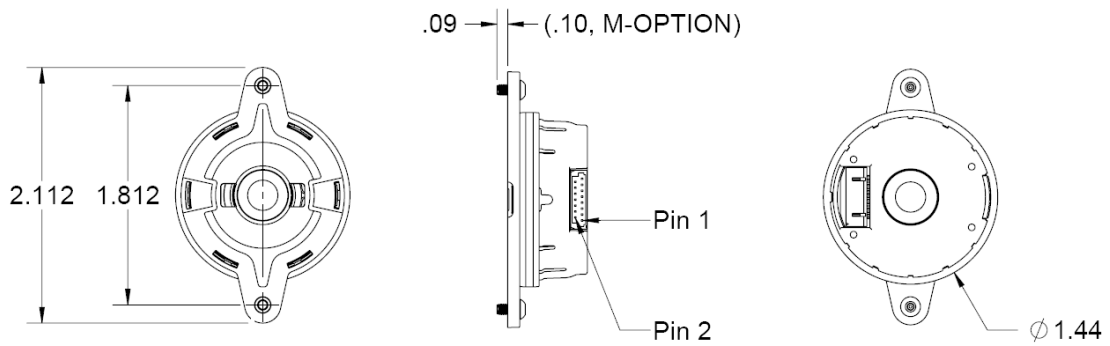

#4-40 x 3/16 SCREWS
QTY 2 SUPPLIED
(M-OPTION SUBSTITUTE M2.5 x 5)

Note: All dimensions are in inches

Pin #	Wire Color	Differential	Open-Collector	0-Pole Option
1	YELLOW	A+ (Quadrature)	A+ (Quadrature)	A+ (Quadrature)
2	YELLOW/WHT	A-	A-	A-
3	BLUE	B+ (Quadrature)	B+ (Quadrature)	B+ (Quadrature)
4	BLUE/WHT	B-	B-	B-
5	ORANGE	Z+ (Index)	Z+ (Index)	Z+ (Index)
6	ORANGE/WHT	Z-	Z-	Z-
7	GREEN	U+ (U Commutation)	U+ (Open-Collector)	No Connection
8	GREEN/WHT	U-	No Connection	No Connection
9	BROWN	V+ (V Commutation)	V+ (Open-Collector)	No Connection
10	BROWN/WHT	V-	No Connection	No Connection
11	WHITE	W+ (W Commutation)	W+ (Open-Collector)	No Connection
12	WHITE/GREY	W-	No Connection	No Connection
13	RED	+5V Power	+5V Power	+5V Power
14	BLACK	GND	GND	GND
15	GREY	No Connection	No Connection	No Connection

*Note: Wire color scheme provided in the table above is for Anaheim Automation's part number: ENC-CBL-CA-E15-SH-NC.

Timing Diagram:

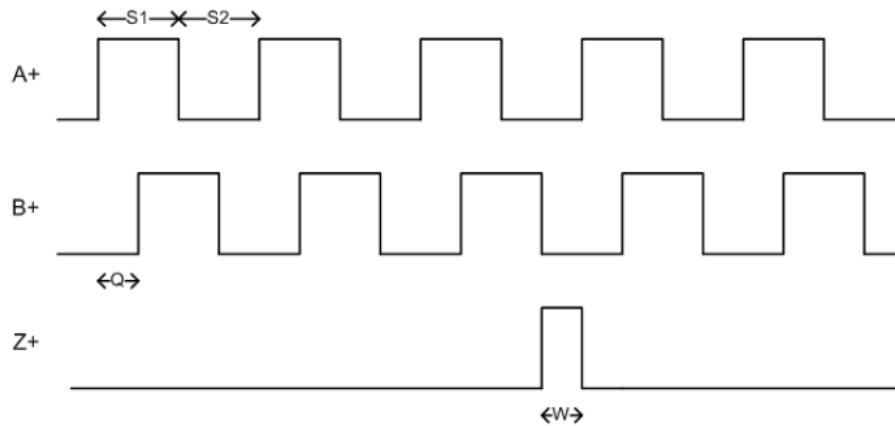

Rotation as viewed from the top of the encoder:
A leads B for CCW rotation, and B leads A for CW rotation.

Motor Poles: 4 (12 States per Revolution)

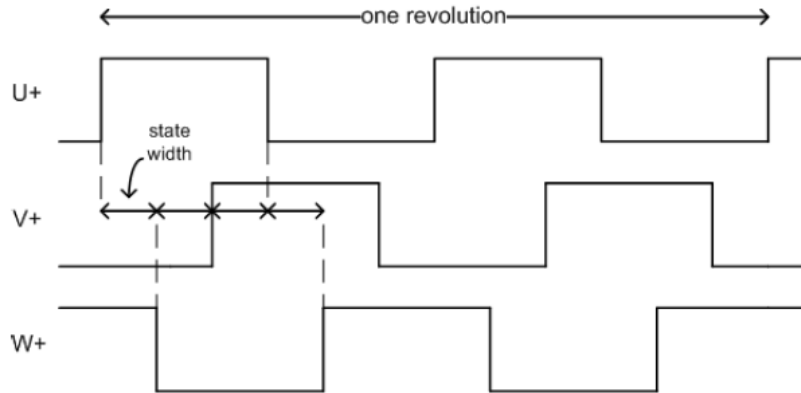

Motor Poles: 6 (18 States per Revolution)

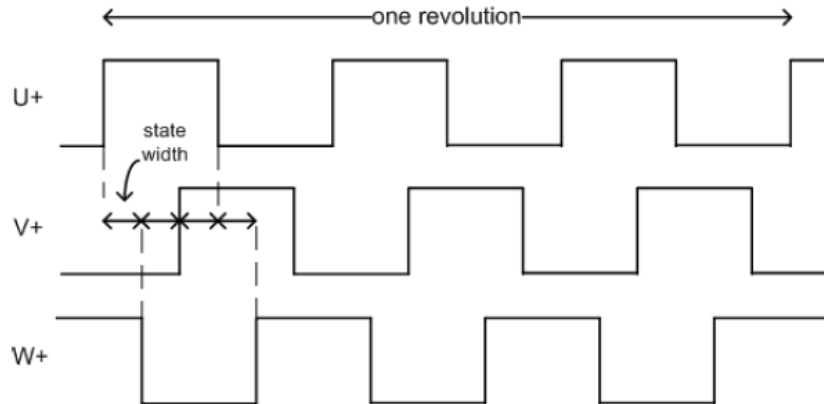

Motor Poles: 8 (24 States per Revolution)

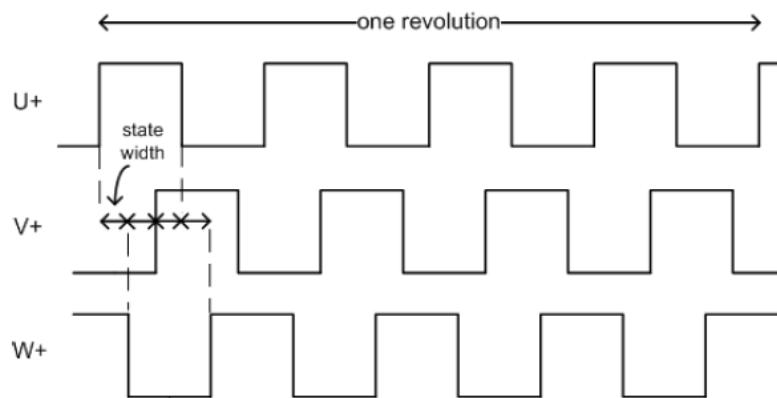

Parameter	Min	Typ	Max	Units
State Width, 4 Pole	27	30	33	Angular Degrees
State Width, 6 Pole	17	20	23	Angular Degrees
State Width, 8 Pole	12	15	18	Angular Degrees
State Width, 10 Pole	9	12	15	Angular Degrees
State Width, 12 Pole	7	10	13	Angular Degrees

Parameter	Min	Typ	Max	Units
Supply Current CPR ≤ 2500, no load, max freq. output	-	13	17	mA
Supply Current CPR > 2500, no load, max freq. output	-	37	44	mA
Differential Output Low (I _{OL} = 8mA max)	-	-	0.5	Volts
Differential Output High I _{OL} = -8mA max	2.5	3.5	-	Volts
Differential Rise / Fall Time	-	100	-	nS
Open-Collector Pullup Voltage	-	-	30	V
Open-Collector "on" Resistance	-	0.2	-	ohm
Frequency Response, CPR ≤ 2500	-	-	400	kHz
Frequency Response, CPR = 4000 or 5000	-	-	800	kHz
Frequency Response' CPR = 10,000	-	-	1.00	MHz
Vibration (10 Hz to 2 kHz)	-	-	20	G
Shaft Axial Play	-	-	± 0.005	in.
Acceleration	-	-	250,000	rad/sec ²
Maximum RPM, CPR ≤ 2500	-	-	24x10 ⁶ / CPR	RPM
Maximum RPM, CPR = 4000	-	-	12,000	RPM
Maximum RPM, CPR = 10,000	-	-	6,000	RPM
Maximum RPM, CPR = 20,000	-	-	3,000	RPM
Maximum RPM, CPR = 40,000	-	-	1,440	RPM
Maximum RPM, CPR = 60,000	-	-	960	RPM
Temperature	-20	-	105	°C
Supply Voltage	4.5	5.5	-	Volts
Load Capacitance	-	100	-	pF

Terminology	Definition
CPR(N):	The Number of Cycles Per Revolution
One Shaft Rotation:	360 mechanical degrees, N cycles
One Electrical Degree (°e):	1/360th of one cycle
One Cycle (C):	360 electrical degrees (°e). Each cycle can be decoded into 1 or 4 codes, referred to as X1 or X4 resolution multiplication
Symmetry:	A measure of the relationship between (X) and (Y) in electrical degrees, nominally 180 °e
Quadrature:	The phase lag or lead between channels A and B in electrical degrees, nominally 90 °e
Index (CH Z):	The Index Output goes high once per revolution, coincident with the low states of channels A and B, nominally 1/4 of one cycle (90°e)

Timing Characteristics	Symbol	Min	Typ	Max	Units
Cycle Error	C	-	3.0	5.5	°e
Symmetry	S1,S2	150	180	210	°e
Quadrature Delay, Q	Q	45	90	135	°e
Index Pulse Width, W	W	45	90	135	°e

Cables:

The following cables are compatible with Anaheim Automation's ENC-EC35 series encoder. Select a cable length from the table below:

Cable Part Number	Length
ENC-CBL-CA-E15-SH-NC-1	1 ft.
ENC-CBL-CA-E15-SH-NC-5	5 ft.
ENC-CBL-CA-E15-SH-NC-10	10 ft.
ENC-CBL-CA-E15-SH-NC-20	20 ft.

Note: To make your own cable connector please refer to the connector manufacturer JAE. The shell is JAE# FI-W15S and the pins are JAE# FI-C3-A1-15000.

Centering Tools:

Centering tools are optional, but recommended for a more precise installation.

ENC-CTOOL - 250

Bore Size	
197 = 5mm	315 = 8mm
236 = 6mm	375 = 3/8"
250 = 1/4"	

NOTE: For pricing and other information on cables and centering tools, please visit Accessories on our website.