

STEPPER MOTOR CONTROLLER

FEATURES:

- Controls Bipolar and Unipolar Motors
- Cost-effective replacement for **L297** in Bipolar applications
- Full, 1/2, 1/4, 1/8, 1/16, 1/32, step mode selected with 3 mode inputs
- Direction control
- Reset input
- Step control input
- Enable input
- PWM chopper circuit for current control
- 8-bit PWM resolution
- Two peak current comparators with external reference input
- Step control frequency and duty cycle controlled by an external frequency source or by an internal crystal controlled oscillator (typically 8MHz)
- All inputs and outputs TTL/CMOS compatible (TTL for 5V operation)
- 3V to 5.5V Operation ($V_{DD} - V_{SS}$).
- **LS7290** (DIP), **LS7290-S** (SOIC), **LS7290-TS** (TSSOP) - See Figure 1 -

DESCRIPTION:

The **LS7290** generates Phase Drive outputs and PWM outputs for controlling two phase Bipolar motors or four phase Unipolar motors, respectively. The **LS7290** contains a mode controlled look-up table for generating the motor duty cycle drive sequences. There are four outputs which are used to drive two H-Bridges for the two motor windings in the Bipolar motor or the four Driver Transistors for the two center-tapped windings in the Unipolar motor (Refer to Table 2). The **LS7290** can step a motor in full steps, half steps or in 1/4, 1/8, 1/16 or 1/32 microsteps. The **LS7290** uses 32 microstepping phase controls for each motor step in half step or in 1/4, 1/8, 1/16 or 1/32 microsteps. The **LS7290** uses stepping as shown in Table 2 for full step control. A table pointer is used which is incremented or decremented by a value determined by the operating mode and the direction control. The 8-bit PWM control and the refresh rate are set using an internal oscillator controlled by a crystal or by use of an external input clock. Typical refresh rate is equal to 31.25kHz. **Peak current feedback control using pulse width modulation chopping can only be used in full-step or half-step modes.** The chopper consists of a voltage comparator, flip-flop and external sense resistor. The internal oscillator sets the flip-flop and enables the $\overline{INH1}$ and $\overline{INH2}$ outputs at the beginning of each PWM cycle. Once the peak motor current causes the voltage across the sense resistors to reach the voltage set by VREF, the outputs are disabled until the next oscillator pulse. The VREF voltage sets the peak current in each motor winding. **In all other modes, the VREF input should be set to V_{DD} and the sense inputs should be grounded.**

INPUT/OUTPUT DESCRIPTION

RESET Input

Active low. Resets the PWM table pointer to HOME position per Table 2 and brings $\overline{INH1}$ and $\overline{INH2}$ low. Upon power-up, a POR circuit also resets the PWM table pointer.

ENABLE Input

Active low. When high (inactive), brings PHA, PHB, PHC, PHD, $\overline{INH1}$ and $\overline{INH2}$ outputs low.

STEP Input

Active low. A low-going pulse on this input causes the motor to advance one step.

PIN ASSIGNMENT TOP VIEW

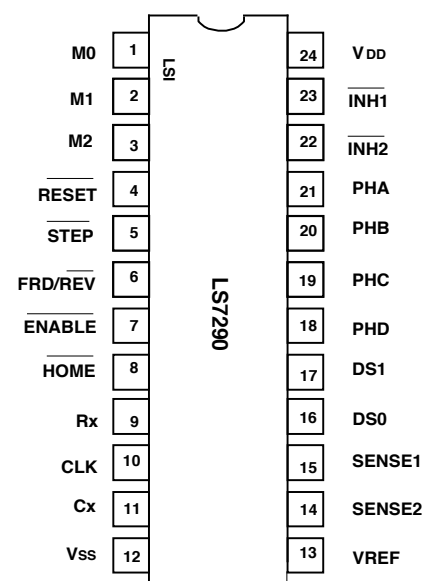

FIGURE 1

FRD/RVRS Input

A low input causes the motor to move in decremental steps per Table 2. A high input causes the motor to move in incremental steps per Table 2. Switching directions can occur at any time.

M0, M1, M2 Inputs

Defines the stepping modes as follows:

	M2	M1	M0
full step mode	0	0	0
1/2 step mode	0	0	1
1/4 step mode	0	1	0
1/8 step mode	0	1	1
1/16 step mode	1	0	0
1/32 step mode	1	0	1
1/32 step mode	1	1	0
1/32 step mode	1	1	1

Stepping Mode can be changed at any time.

SENSE1 / SENSE2 Inputs

SENSE1 is the input for the voltage across the sense resistor determined by the current in the motor winding driven by the PHA and PHB power stages. SENSE2 is the input for the voltage across the sense resistor determined by the current in the motor winding driven by the PHC and PHD power stages.

VREF Input

External voltage reference for current control comparators.

Rx, Cx, CLK

These three pins can be configured in one of three ways to obtain the primary clock. A crystal connected between Rx and CLK pins or a resistor-capacitor pair connected among all three pins (see Figure 4) can make use of the internal oscillator. Alternatively, the CLK pin can be driven from an external clock source.

DS0 / DS1 Inputs

The phase drive is blanked out between steps by switching outputs INH1 and INH2 low in order to reduce audible noise and power consumption. The duration of the blanking is selected by DS0 and DS1 according to Table 1

PHA / PHB / PHC / PHD Outputs

The state of these phase outputs are determined by the look-up table and are used to control either the left or right half of each of the H-Bridge drivers. A low on a phase output enables the bottom driver while a high on the output enables the top driver.

HOME Output

Indicates Step0 state per Table 2 with a logic low.

INH1 / INH2 Outputs

These outputs are used to provide PWM control to each of the two H-Bridge drivers.

Table 1

DS1	DS0	Blanking Time, IPB, at fc = 8MHz
0	0	1.25us
0	1	2.50us
1	0	3.75us
1	1	5.00us

The information included herein is believed to be accurate and reliable. However, LSI Computer Systems, Inc. assumes no responsibilities for inaccuracies, nor for any infringements of patent rights of others which may result from its use.

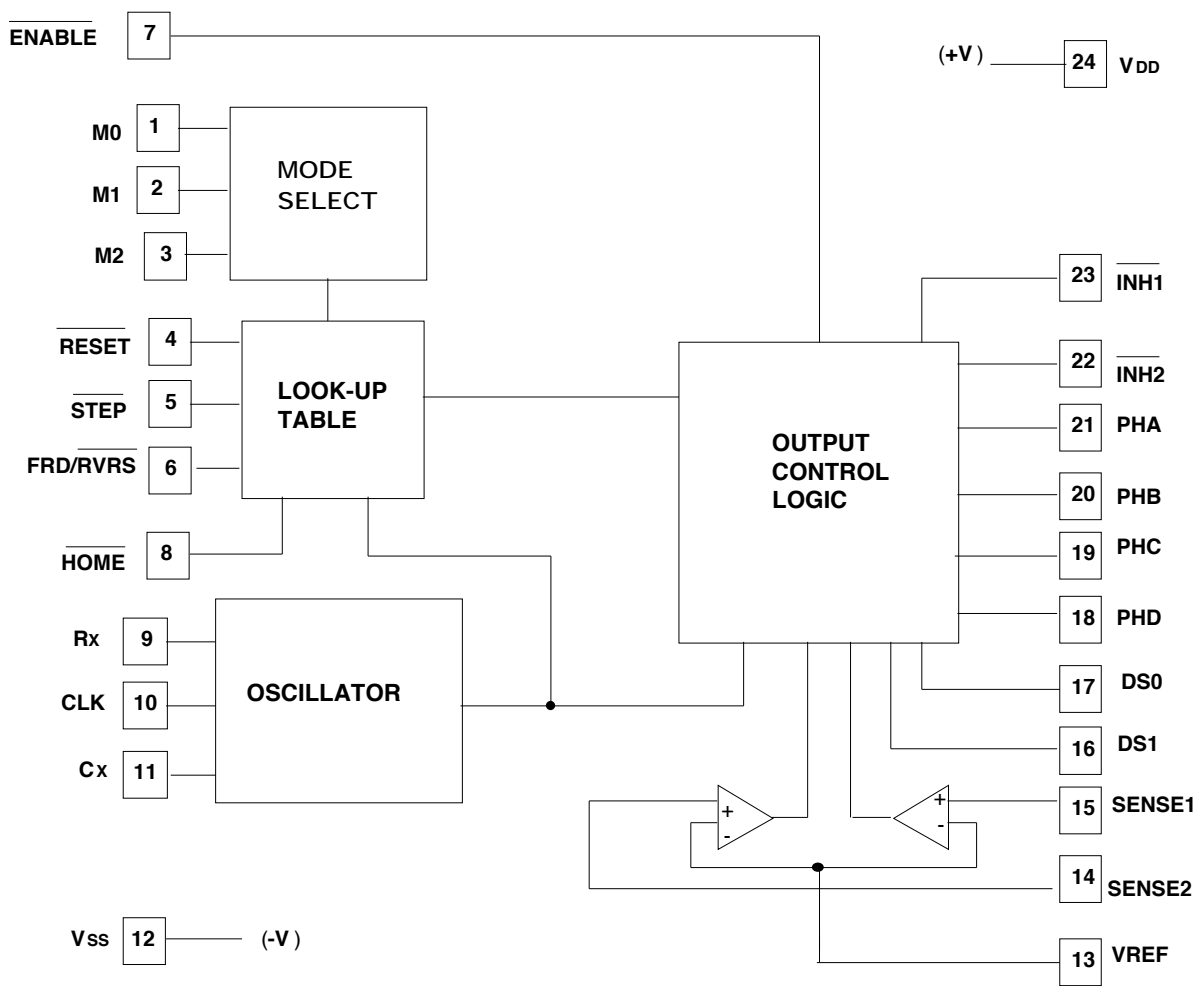

FIGURE 2. LS7290 BLOCK DIAGRAM

ABSOLUTE MAXIMUM RATINGS:

PARAMETER	SYMBOL	VALUE	UNIT
DC Supply Voltage	V _{DD} - V _{SS}	+7	V
Any Input Voltage	V _{IN}	V _{SS} - 0.3 to V _{DD} +0.3	V
Operating Temperature	T _A	-20 to +85	°C
Storage Temperature	T _{STG}	-85 to +150	°C

ELECTRICAL SPECIFICATIONS (-25°C < T_A < +85°C)

PARAMETER	SYMBOL	MIN	TYP	MAX	UNIT	CONDITIONS
Supply Voltage	V _{DD}	3.0	-	5.5	V	-
Supply Current	I _{DD}	-	-	2.0	mA	Outputs floating, Inputs high
CLK frequency	f _c	-	8.00	-	MHz	-
Enable Propagation Delay	t _{epd}	100	-	-	ns	-
FRD / RVRS Setup Time (before step pulse)	t _{ds}	0	-	-	us	-
Step Pulse Width	SPW	1.0	-	-	us	at f _c = 8 MHz
Interstep Pulse Delay	ISD	32	-	-	us	at f _c = 8 MHz
Interstep Phase Blanking	IPB	1.25	-	5.0	us	at f _c = 8 MHz
Reset Pulse Width	RPW	1.0	-	-	us	at f _c = 8 MHz
Reset to Step Pulse Delay	t _{rs}	0	-	-	us	-
Hi-Level Input Voltage	V _{IH}	2	-	-	V	V _{DD} = 5 ± 0.25V
Low-Level Input Voltage	V _{IL}	-	-	0.8	V	V _{DD} = 5 ± 0.25V
Hi-Level Input Current	I _H	-	-	50	nA	Leakage Current
Low-Level Input Current	I _L	-	-	50	nA	Leakage Current
Output Sink Current	I _o	-10	-	-	mA	V _o = 0.4V, V _{DD} = 5V
	I _o	-5	-	-	mA	V _o = 0.4V, V _{DD} = 3.3V
Output Source Current	I _o	5	-	-	mA	V _o = 4.0V, V _{DD} = 5V
	I _o	2.5	-	-	mA	V _o = 2.5V, V _{DD} = 3.3V
Comparator Offset Voltage	V _{OS}	-	5	15	mV	V _{REF} = 1V
Input Reference Voltage	V _{REF}	0.5	-	3.0	V	V _{DD} = 5V
	V _{REF}	0.5	-	1.5	V	V _{DD} = 3.3V

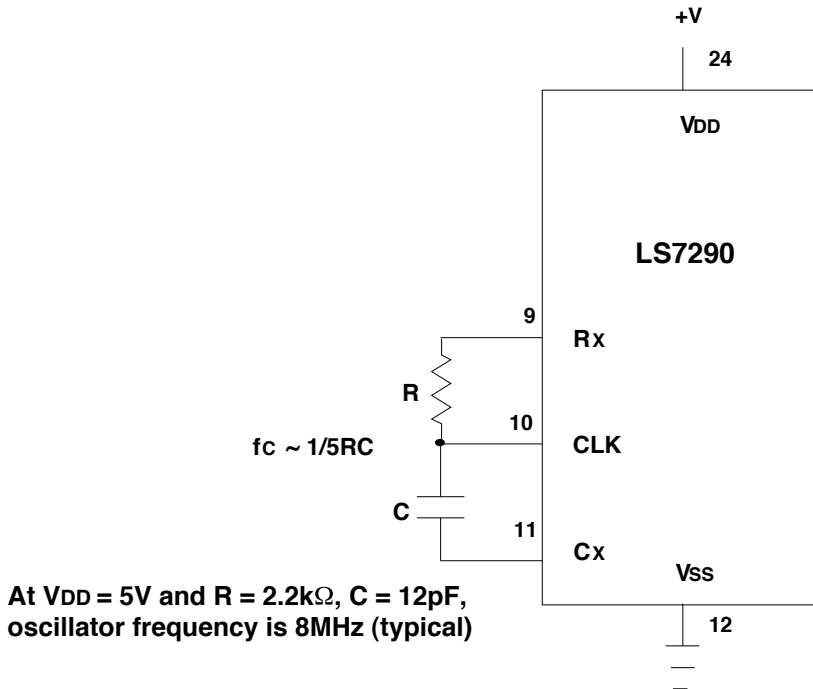

FIGURE 3. RC OSCILLATOR FOR CLOCK GENERATOR

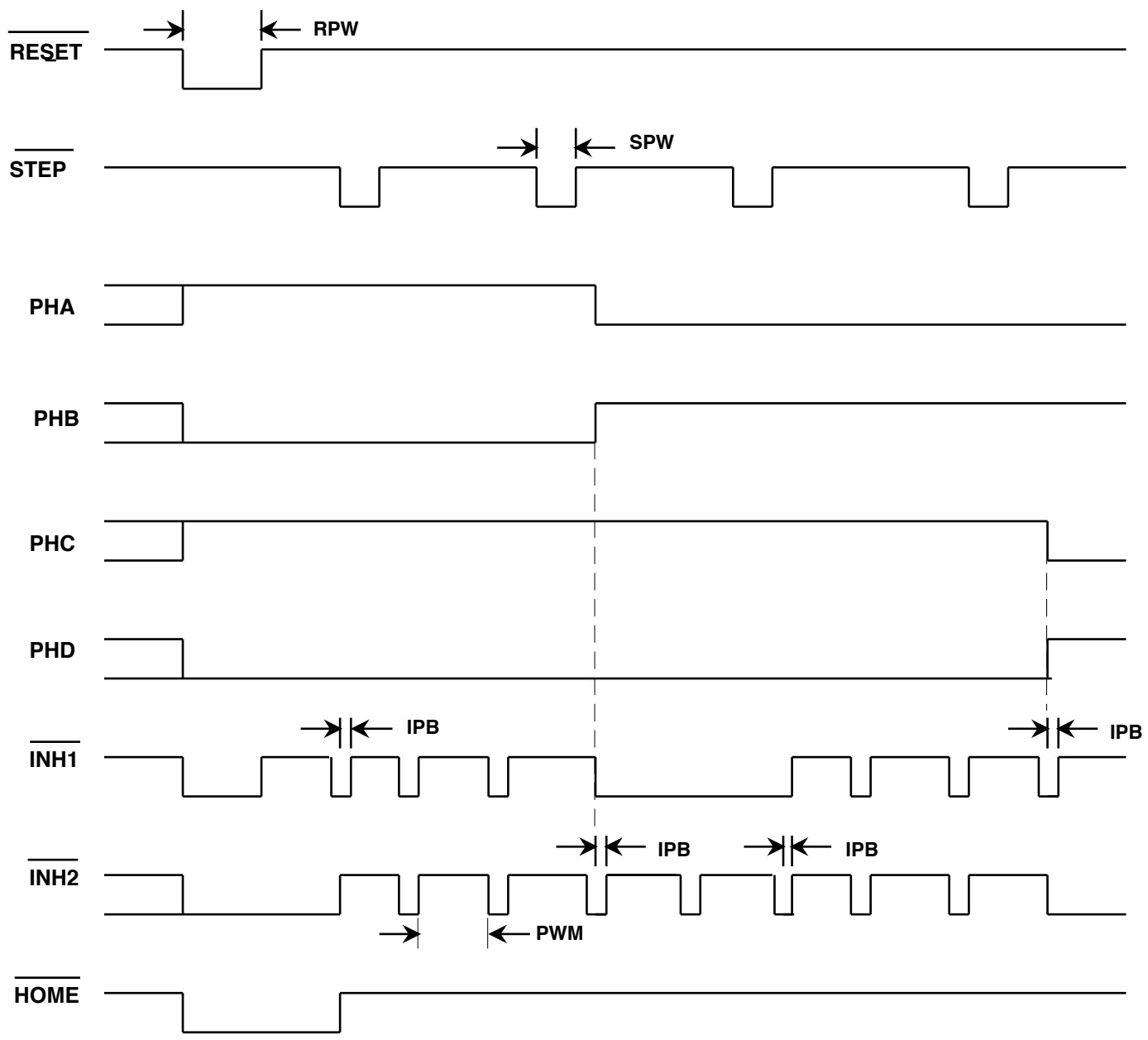

FIGURE 4. PARTIAL SEQUENCE IN FORWARD 1/2 STEP MODE

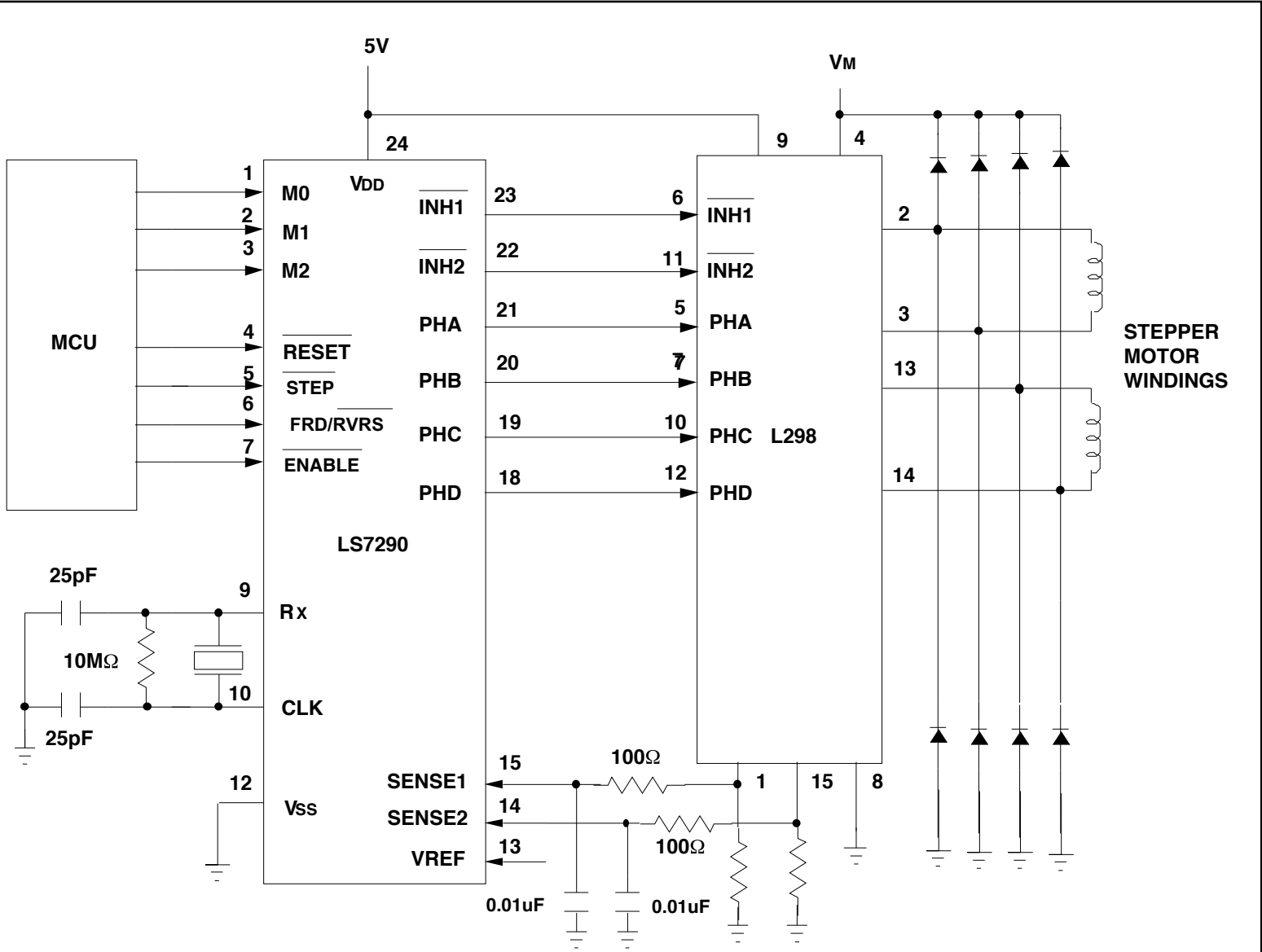

FIGURE 5. TYPICAL APPLICATION SCHEMATIC FOR A TWO PHASE BIPOLAR MOTOR USING A SINGLE MOTOR DRIVER IC

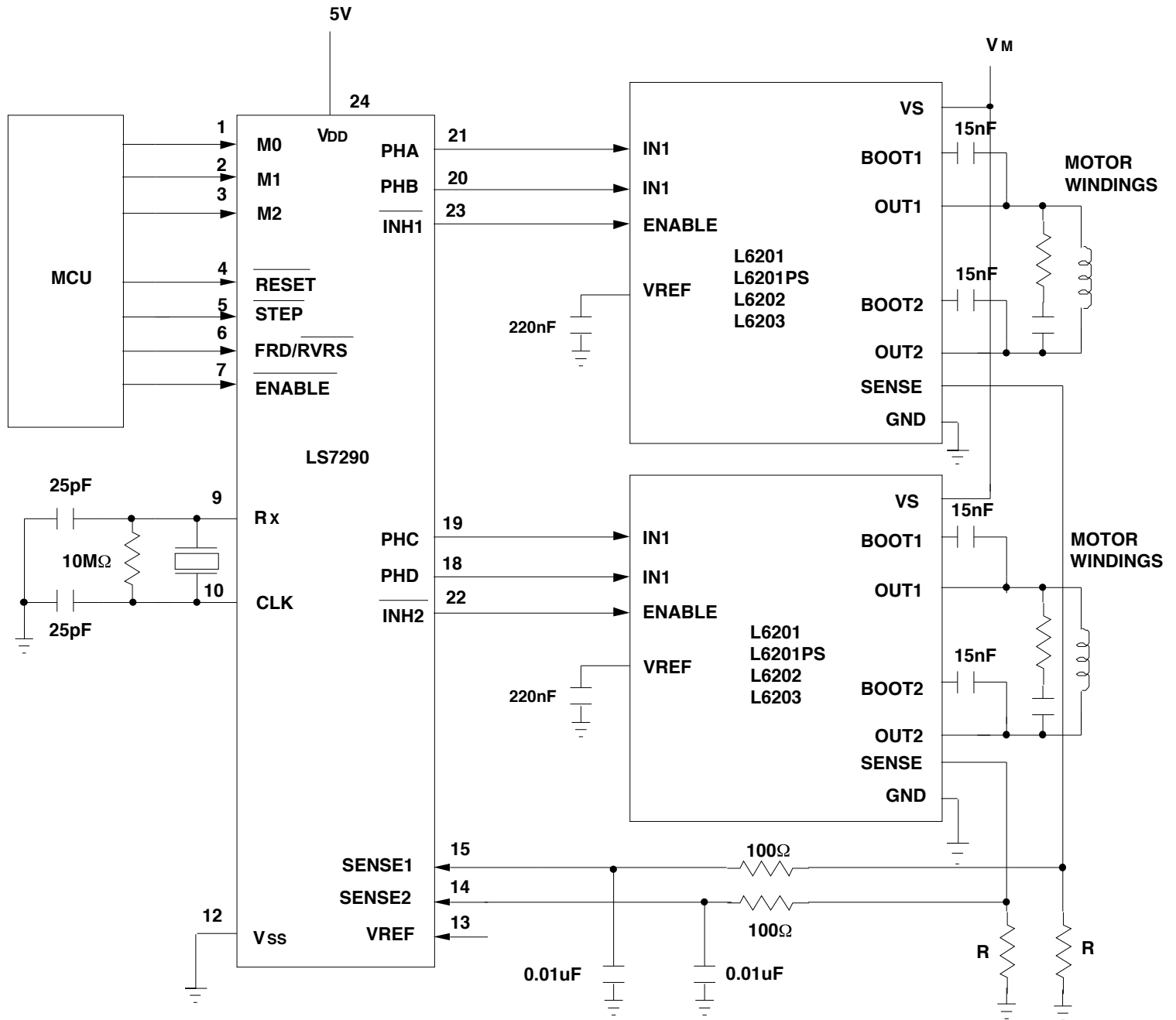
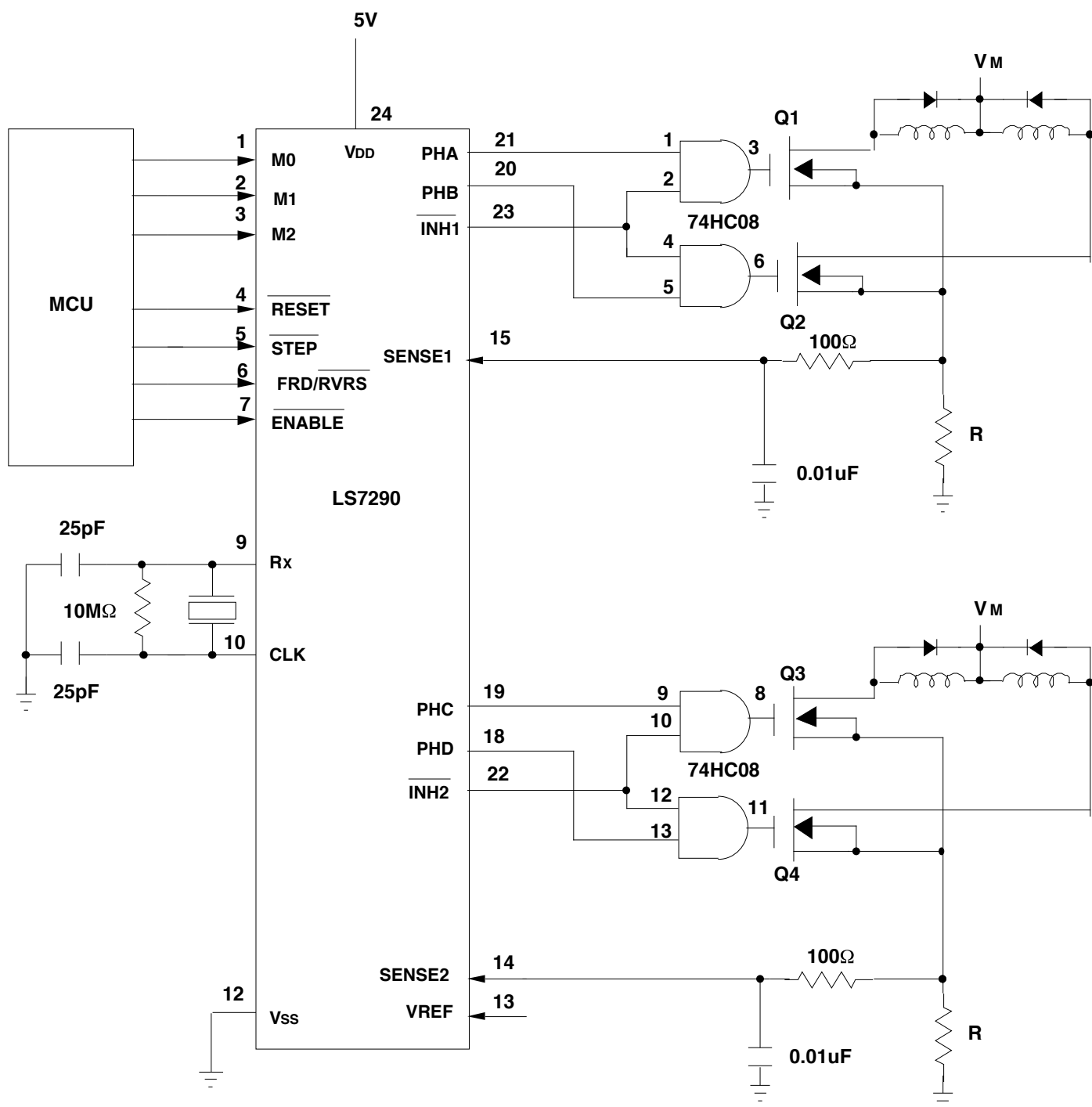

FIGURE 6. TYPICAL APPLICATION SCHEMATIC FOR A TWO PHASE BIPOLAR MOTOR USING TWO SEPARATE MOTOR DRIVER ICs



**NOTE: Q1, Q2, Q3, Q4 are MOSFET Power Transistors suitable for 5V Gate Drive
 Typical P/Ns = IRLZ44N and IRF3708**

FIGURE 7. TYPICAL APPLICATION SCHEMATIC FOR A FOUR PHASE UNIPOLAR MOTOR USING DISCRETE MOSFET TRANSISTORS

TABLE 2

Step Number						% Duty Cycle		Phases				Step Angle
Full	1/2	1/4	1/8	1/16	1/32	INH1	INH2	PHA	PHB	PHC	PHD	
0	0	0	0	0	0	100.0	0.0	1	0	1	0	HOME
					1	99.9	4.9	1	0	1	0	2.81
				1	2	99.5	9.8	1	0	1	0	5.63
					3	98.9	14.7	1	0	1	0	8.44
			1	2	4	98.1	19.5	1	0	1	0	11.25
					5	97.0	24.3	1	0	1	0	14.06
				3	6	95.7	29.0	1	0	1	0	16.88
					7	94.2	33.7	1	0	1	0	19.69
		1	2	4	8	92.4	38.3	1	0	1	0	22.50
					9	90.4	42.8	1	0	1	0	25.31
				5	10	88.2	47.1	1	0	1	0	28.13
					11	85.8	51.4	1	0	1	0	30.94
			3	6	12	83.1	55.6	1	0	1	0	33.75
					13	80.3	59.6	1	0	1	0	36.56
				7	14	77.3	63.4	1	0	1	0	39.38
					15	74.1	67.2	1	0	1	0	42.19
	1	2	4	8	16	70.7	70.7	1	0	1	0	45.00
					17	67.2	74.1	1	0	1	0	47.81
				9	18	63.4	77.3	1	0	1	0	50.63
					19	59.6	80.3	1	0	1	0	53.44
			5	10	20	55.6	83.1	1	0	1	0	56.25
					21	51.4	85.8	1	0	1	0	59.06
				11	22	47.1	88.2	1	0	1	0	61.88
					23	42.8	90.4	1	0	1	0	64.69
		3	6	12	24	38.3	92.4	1	0	1	0	67.50
					25	33.7	94.2	1	0	1	0	70.31
				13	26	29.0	95.7	1	0	1	0	73.13
					27	24.3	97.0	1	0	1	0	75.94
			7	14	28	19.5	98.1	1	0	1	0	78.75
					29	14.7	98.9	1	0	1	0	81.56
				15	30	9.8	99.5	1	0	1	0	84.38
					31	4.9	99.9	1	0	1	0	87.19
1	2	4	8	16	32	0.0	100.0	0	1	1	0	90.00
					33	-4.9	99.9	0	1	1	0	92.81
				17	34	-9.8	99.5	0	1	1	0	95.63
					35	-14.7	98.9	0	1	1	0	98.44
			9	18	36	-19.5	98.1	0	1	1	0	101.25
					37	-24.3	97.0	0	1	1	0	104.06
				19	38	-29.0	95.7	0	1	1	0	106.88

TABLE 2 (continued)

Step Number					% Duty Cycle		Phases				Step Angle	
Full	1/2	1/4	1/8	1/16	1/32	INH1	INH2	PHA	PHB	PHC		PHD
					39	-33.7	94.2	0	1	1	0	109.69
		5	10	20	40	-38.3	92.4	0	1	1	0	112.50
					41	-42.8	90.4	0	1	1	0	115.31
				21	42	-47.1	88.2	0	1	1	0	118.13
					43	-51.4	85.8	0	1	1	0	120.94
			11	22	44	-55.6	83.1	0	1	1	0	123.75
					45	-59.6	80.3	0	1	1	0	126.56
				23	46	-63.4	77.3	0	1	1	0	129.38
					47	-67.2	74.1	0	1	1	0	132.19
	3	6	12	24	48	-70.7	70.7	0	1	1	0	135.00
					49	-74.1	67.2	0	1	1	0	137.81
				25	50	-77.3	63.4	0	1	1	0	140.63
					51	-80.3	59.6	0	1	1	0	143.44
			13	26	52	-83.1	55.6	0	1	1	0	146.25
					53	-85.8	51.4	0	1	1	0	149.06
				27	54	-88.2	47.1	0	1	1	0	151.88
					55	-90.4	42.8	0	1	1	0	154.69
		7	14	28	56	-92.4	38.3	0	1	1	0	157.50
					57	-94.2	33.7	0	1	1	0	160.31
				29	58	-95.7	29.0	0	1	1	0	163.13
					59	-97.0	24.3	0	1	1	0	165.94
			15	30	60	-98.1	19.5	0	1	1	0	168.75
					61	-98.9	14.7	0	1	1	0	171.56
				31	62	-99.5	9.8	0	1	1	0	174.38
					63	-99.9	4.9	0	1	1	0	177.19
2	4	8	16	32	64	-100.0	0.0	0	1	0	1	180.00
					65	-99.9	-4.9	0	1	0	1	182.81
				33	66	-99.5	-9.8	0	1	0	1	185.63
					67	-98.9	-14.7	0	1	0	1	188.44
			17	34	68	-98.1	-19.5	0	1	0	1	191.25
					69	-97.0	-24.3	0	1	0	1	194.06
				35	70	-95.7	-29.0	0	1	0	1	196.88
					71	-94.2	-33.7	0	1	0	1	199.69
		9	18	36	72	-92.4	-38.3	0	1	0	1	202.50
					73	-90.4	-42.8	0	1	0	1	205.31
				37	74	-88.2	-47.1	0	1	0	1	208.13
					75	-85.8	-51.4	0	1	0	1	210.94
			19	38	76	-83.1	-55.6	0	1	0	1	213.75
					77	-80.3	-59.6	0	1	0	1	216.56
				39	78	-77.3	-63.4	0	1	0	1	219.38
					79	-74.1	-67.2	0	1	0	1	222.19
	5	10	20	40	80	-70.7	-70.7	0	1	0	1	225.00
					81	-67.2	-74.1	0	1	0	1	227.81
				41	82	-63.4	-77.3	0	1	0	1	230.63
					83	-59.6	-80.3	0	1	0	1	233.44

TABLE 2 (continued)

Step Number						% Duty Cycle		Phases				Step Angle
Full	1/2	1/4	1/8	1/16	1/32	INH1	INH2	PHA	PHB	PHC	PHD	
			21	42	84	-55.6	-83.1	0	1	0	1	236.25
					85	-51.4	-85.8	0	1	0	1	239.06
				43	86	-47.1	-88.2	0	1	0	1	241.88
					87	-42.8	-90.4	0	1	0	1	244.69
		11	22	44	88	-38.3	-92.4	0	1	0	1	247.50
					89	-33.7	-94.2	0	1	0	1	250.31
				45	90	-29.0	-95.7	0	1	0	1	253.13
					91	-24.3	-97.0	0	1	0	1	255.94
			23	46	92	-19.5	-98.1	0	1	0	1	258.75
					93	-14.7	-98.9	0	1	0	1	261.56
				47	94	-9.8	-99.5	0	1	0	1	264.38
					95	-4.9	-99.9	0	1	0	1	267.19
3	6	12	24	48	96	0.0	-100	1	0	0	1	270.00
					97	4.9	-99.9	1	0	0	1	272.81
				49	98	9.8	-99.5	1	0	0	1	275.63
					99	14.7	-98.9	1	0	0	1	278.44
			25	50	100	19.5	-98.1	1	0	0	1	281.25
					101	24.3	-97.0	1	0	0	1	284.06
				51	102	29.0	-95.7	1	0	0	1	286.88
					103	33.7	-94.2	1	0	0	1	289.69
		13	26	52	104	38.3	-92.4	1	0	0	1	292.50
					105	42.8	-90.4	1	0	0	1	295.31
				53	106	47.1	-88.2	1	0	0	1	298.13
					107	51.4	-85.8	1	0	0	1	300.94
			27	54	108	55.6	-83.1	1	0	0	1	303.75
					109	59.6	-80.3	1	0	0	1	306.56
				55	110	63.4	-77.3	1	0	0	1	309.38
					111	67.2	-74.1	1	0	0	1	312.19
	7	14	28	56	112	70.7	-70.7	1	0	0	1	315.00
					113	74.1	-67.2	1	0	0	1	317.81
				57	114	77.3	-63.4	1	0	0	1	320.63
					115	80.3	-59.6	1	0	0	1	323.44
			29	58	116	83.1	-55.6	1	0	0	1	326.25
					117	85.8	-51.4	1	0	0	1	329.06
				59	118	88.2	-47.1	1	0	0	1	331.88
					119	90.4	-42.8	1	0	0	1	334.69
		15	30	60	120	92.4	-38.3	1	0	0	1	337.50
					121	94.2	-33.7	1	0	0	1	340.31
				61	122	95.7	-29.0	1	0	0	1	343.13
					123	97.0	-24.3	1	0	0	1	345.95
			31	62	124	98.1	-19.5	1	0	0	1	348.75
					125	98.9	-14.7	1	0	0	1	351.56
				63	126	99.5	-9.8	1	0	0	1	354.38
					127	99.9	-4.9	1	0	0	1	357.19
0	0	0	0	0	0	100.0	0.0	1	0	1	0	HOME

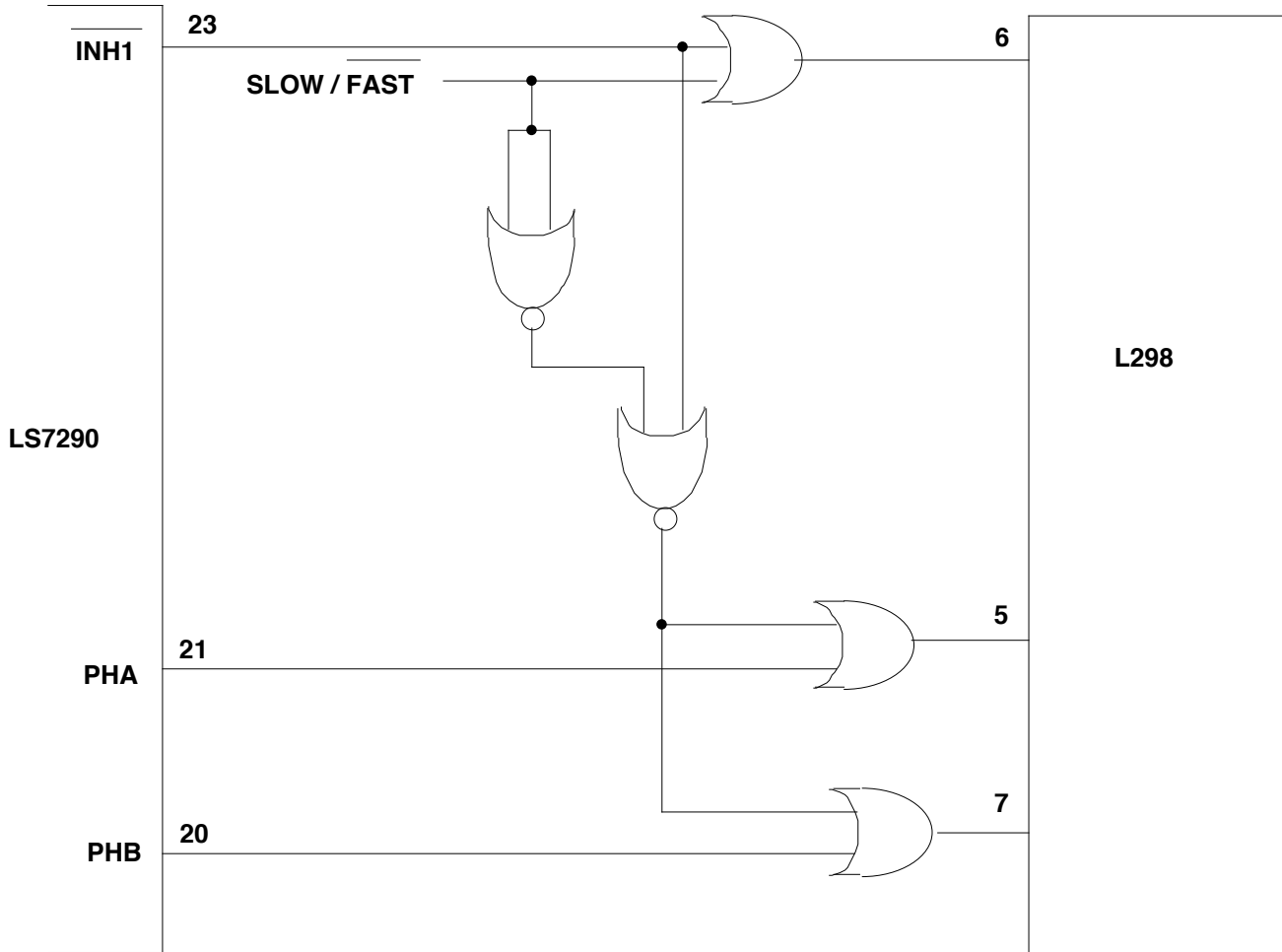

**FIGURE 8. Selecting Between Fast and Slow Decay for One Stepper Motor Winding
(Use identical circuit for the other stepper motor winding)**

**NOTE: In fast decay mode, inhibit windings are chopped.
In slow decay mode mode, phase windings are chopped**

NOR Gates: CD4001 OR Gates: CD4071

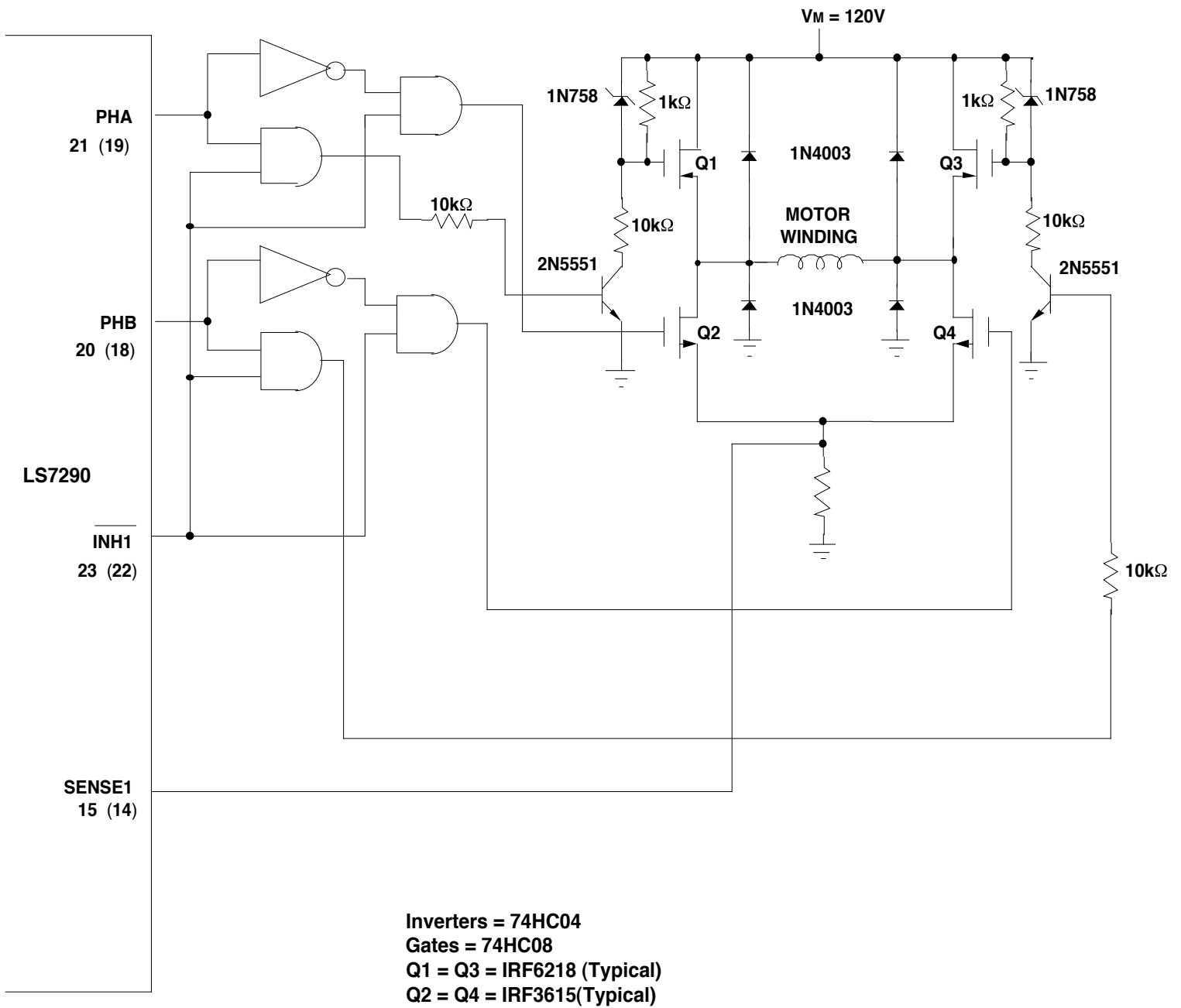

FIGURE 9. 120V Motor Discrete Component Driver