

Standard "D" Series Step Motors - NEMA 23, 34 and 42

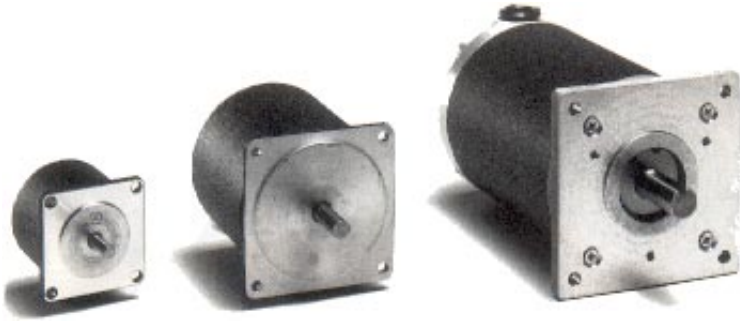

General Specifications:

Step Angle: 1.8° (200 steps/rev.)

Step Accuracy: +5% of one step, non-cumulative

Ambient Temperature: -20° C to 50° C

Maximum Case Temperature: 100° C

Insulation: NEMA Class B

Insulation Resistance: 1000M Ohms at 500VDC @25 ° C

Anaheim Automation's D Series Standard Step Motors are 4-phase hybrid, 1.8 degree motors. They are available in NEMA 23, 34, and 42 frame sizes with current ratings ranging from 1.0 amps/phase to 12.7 amps/phase. These motors offer 200 steps/revolution (Full-step) and are ideal for Half-step and Microstep operation. The standard 23 and 34 frame motors are available in 6 and 8 flying lead configurations, while the 42 frame motor is configured with a conduit box. Options for the 23 and 34 frame motors are double-ended shafts and encoder provisions. The 34 frame motor can also be configured with a conduit box.

WIRING INSTRUCTIONS:

Before wiring step motor(s), it is recommended that some initial checks are performed. These checks involve taking resistance readings, using an ohm-meter that can resolve 0.1 ohms or better.

MOTOR CHECK:

Set ohm-meter to highest scale available. Do a resistance check between each motor lead (6 total) and the motor face plate. The resistance in each case should be infinite. Tie both common leads together and connect meter from leads to face plate. Slowly rotate motor one complete revolution and make sure the reading is infinite. If either of these test show a connection to the face plate, **DO NOT** wire motor to driver. If the motor passes this check, wire the motor to the driver and then **RE-CHECK TO MAKE SURE EACH WIRE IS CONNECTED TO THE PROPER TERMINAL**. Set ohm-meter to lowest scale available and read the resistance between Phase 1 and Common Phase 1 & 3. This resistance reading will be determined by the motor's per phase resistance, plus any wiring between the drive and motor. Next, read the resistance between Phase 3 and Common Phase 1 & 3. This reading should be the same as above (± 0.1 ohm). Finally, read between Phase 1 and Phase 3. This reading will be approximately 1.5 times the phase reading. Perform this test for Phase 2 and Phase 4 to Common Phase 2 & 4. These readings should be the same as the previous tests. For an 8 lead motor connect the ORG/WHT & BLK/WHT wires together to be Common Phase 1 & 3, and the RED/WHT & YEL/WHT wires together to be Common Phase 2 & 4. Proceed as above to check the wiring with the motor now configured like a 6 lead motor.

IF ANY OF THE READINGS APPEAR TO BE INCORRECT, DO NOT APPLY POWER TO THE DRIVER. DISCONNECT THE MOTOR FROM THE DRIVER AND CONTACT ANAHEIM AUTOMATION. If all readings are correct, set the Kick Current potentiometer to the required setting for the motor.

WARNING:

Dangerous voltages capable of causing death, may be present in this equipment. Use caution when handling, testing and adjusting during installation, set-up and operation.

GROUNDING:

All equipment and motors must be securely mounted and adequately grounded. Failure to ground properly may cause damage to the equipment or injury to the user.

**Perfect Replacement
for the Superior
Electric SloSyn MO
Series Step Motors**

See website www.anaheimautomation.com to select a matched driver and controller, and to review speed/torque performance curves



ANAHEIM AUTOMATION

910 East Orangefair Lane, Anaheim, CA 92801
e-mail: info@anaheimautomation.com

(714) 992-6990 fax: (714) 992-0471
website: www.anaheimautomation.com

Standard Step Motor Listing - "D" Series

4 PHASE HYBRID, 1.8°, ±5% STEP ANGLE

Model Number	Holding Torque 2 phases on (oz.in.)		Peak Torque with 60Vdc Bilevel Drive		Voltage per Phase (V/phase)	Current per Phase (A/phase)		Resistance per Phase (ohms/ phase)	Inductance per Phase (mH/phase)	Nominal Rotor Inertia (oz-in-sec ²)	Shaft Diameter (in.)	Maximum Motor Lenth (in.)
	UNIPOLAR	BIPOLAR	2.5RPS	20RPS		UNIPOLAR	BIPOLAR SERIES					
23D102	53	75	55	38	5.1	1.0	.70	5.10	10.0	.0015	.250	2.00
23D104	53	75	53	52	3.0	2.0	1.4	1.50	2.50	.0015	.250	2.00
23D108	53	75	58	44	1.3	3.9	2.7	0.33	0.63	.0015	.250	2.00
23D204	100	140	95	68	4.7	1.8	1.3	2.60	5.70	.003	.250	3.25
23D209	100	140	82	77	1.7	4.7	3.3	0.37	0.80	.003	.250	3.25
23D306	150	210	120	90	3.4	2.9	2.0	1.16	2.90	.0045	.250	4.00
23D309	150	210	115	108	2.2	4.6	3.3	0.48	1.20	.0045	.250	4.00
34D106	150	210	180	118	2.9	3.0	2.1	0.95	3.80	.00975	.375	2.45
34D109	150	210	160	150	1.9	4.8	3.4	0.39	1.60	.00975	.375	2.45
34D207	300	420	280	92	3.5	3.5	2.5	1.00	4.25	.0195	.375	3.7
34D209	300	420	272	170	2.5	4.6	3.3	0.55	2.70	.0195	.375	3.7
34D213	300	420	261	232	2.1	6.5	4.6	0.32	1.25	.0195	.375	3.7
34D307	450	630	465	98	4.5	3.5	2.5	1.29	7.00	.0285	.375	5.3
34D311	450	630	400	175	2.9	5.5	3.9	0.52	2.90	.0285	.375	5.3
34D314	450	630	360	245	2.2	7.0	5.0	0.31	1.70	.0285	.375	5.3
42D112	625	875	602	175	2.3	6.1	4.3	0.38	3.00	.0546	.625	4.74
42D119	625	875	520	483	1.5	9.5	6.7	0.16	0.88	.0546	.625	4.74
42D212	1125	1575	804	201	3.6	6.1	4.3	0.59	5.94	.1105	.625	6.99
42D219	1125	1575	807	477	2.1	9.2	6.5	0.30	2.00	.1105	.625	6.99
42D225	1125	1575	670	600	1.8	12.7	8.9	0.14	1.00	.1105	.625	6.99

Required Suffix: Select either S or D

- S = Single-ended Shaft
- D = Double-ended Shaft

Optional Suffixes:

- LW8 = Eight Lead Configuration
- XCB = Conduit Box Configuration for 34 frame motors

A N A H E I M A U T O M A T I O N

Standard Step Motor Dimensions - "D" Series

NEMA 23

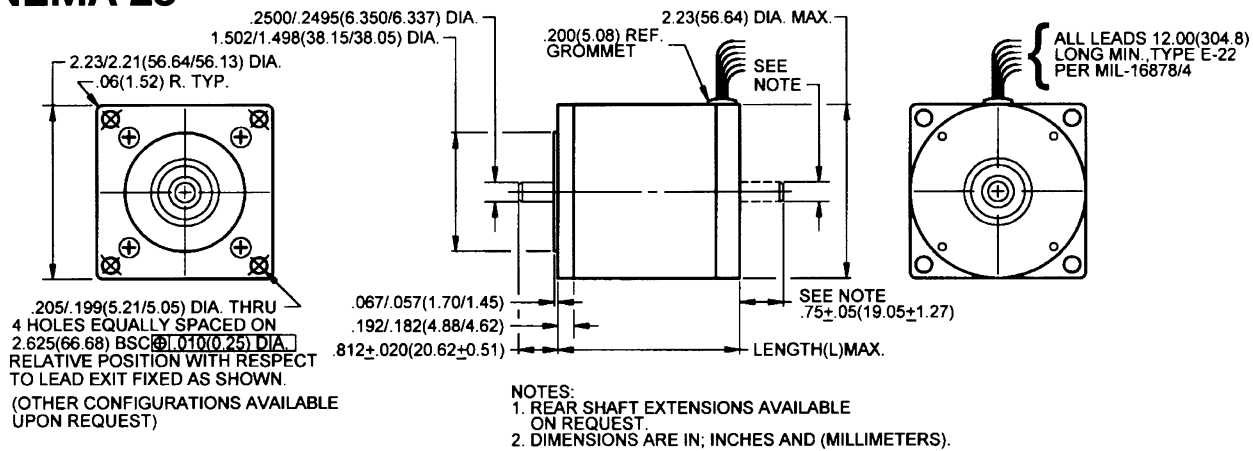

NEMA 34

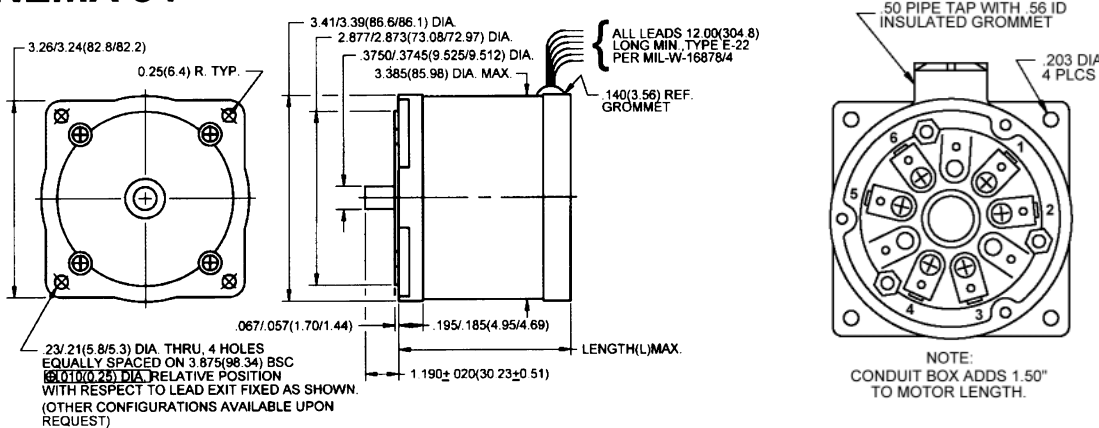

NEMA 42

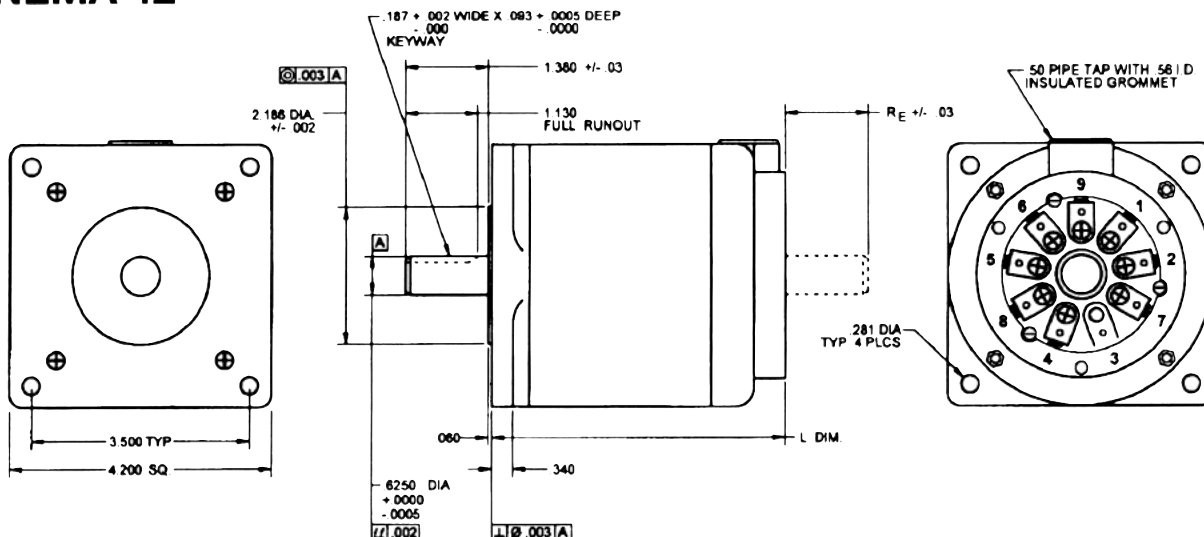

ANAHEIM AUTOMATION

Standard Step Motor Wiring - "D" Series

8-Lead Configuration - Flying Leads and 42 frame Conduit Box

CONNECTION	LEAD NAME	LEAD COLOR	TERMINAL # FOR 42 FRAME CB MOTOR
4 LEAD BIPOLAR SERIES	A	BLACK (BLK)	9
	/A	ORANGE (ORG)	2
	B	RED	1
	/B	YELLOW (YEL)	7
	Tied Together	WHT/BLK & WHT/ORG	5 & 6
	Tied Together	WHT/RED & WHT/YEL	8 & 4
4 LEAD BIPOLAR PARALLEL	A	BLK & WHT/ORG	9 & 5
	/A	ORG & WHT/BLK	6 & 2
	B	RED & WHT/YEL	1 & 4
	/B	YEL & WHT/RED	8 & 7
6 LEAD UNIPOLAR	PHASE 1	BLACK (BLK)	9
	PHASE 3	ORANGE (ORG)	2
	PHASE 2	RED	1
	PHASE 4	YELLOW (YEL)	7
	COMMON 1 & 3	WHT/BLK & WHT/ORG	6 & 5
	COMMON 2 & 4	WHT/RED & WHT/YEL	8 & 4

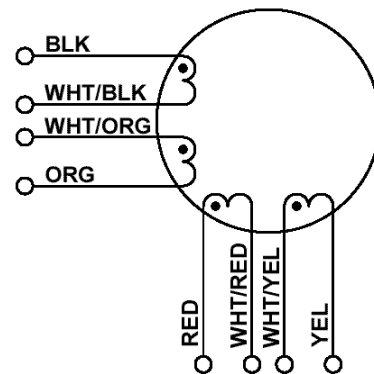

Model Number	Motor Cable
CBL-16AWG-06C	6 Conductor, 16 Gauge, Shielded
CBL-18AWG-04C	4 Conductor, 18 Gauge, Twisted Pair, Shielded

Also Available from Anaheim Automation is a wide variety of "High Torque Motors"

6-Lead Configuration - Flying Leads and 34 frame Conduit Box

CONNECTION	LEAD NAME	LEAD COLOR	TERMINAL # FOR 34 FRAME CB MOTOR
4 LEAD BIPOLAR SERIES	A	RED	4
	/A	RED/WHT	5
	B	GREEN (GRN)	1
	/B	GRN/WHT	3
	NONE	BLACK (BLK)	2
	NONE	WHITE (WHT)	6
6 LEAD UNIPOLAR	PHASE 1	RED	4
	PHASE 3	RED/WHT	5
	PHASE 2	GREEN (GRN)	1
	PHASE 4	GRN/WHT	3
	COMMON 1 & 3	BLACK (BLK)	2
	COMMON 2 & 4	WHITE (WHT)	6

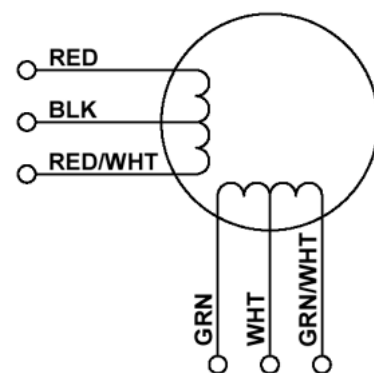

A N A H E I M A U T O M A T I O N