

MLA05101 Bipolar Microstep Driver

User's Guide



ANAHEIM AUTOMATION

4985 E. Landon Drive Anaheim, CA 92807
e-mail: info@anaheimautomation.com

(714) 992-6990 fax: (714) 992-0471
website: www.anaheimautomation.com

MLA05101 Driver Features

- Size (7.30"L x 3.79"W x 1.51"H)
- Output Current 5.0 Amps Peak
- Built in Short Circuit and Mis-Wire Shut Down
- Fixed Step Resolution of 2000 Steps per Revolution
- No Minimum Inductance
- Optical Isolation of Control Inputs
- Motor ON/OFF Input

General Description

The MLA05101 Microstep Motor Driver has an output current capability of 0.75 Amps minimum to 5.0 Amps maximum (Peaking Rating). The MLA05101 driver operates from an AC voltage of 90-132 Volts. The inputs are optically isolated with a minimum sourcing of 1.0 mA per input (+3.5VDC minimum to +8.6VDC maximum). The clock input is set to receive either positive or negative edge clocks with a maximum frequency of 100KHz. The MLA05101 driver offers direction control, motor current ON/OFF capabilities, and built in short circuit and mis-wire shutdown. The Reduce Current Enabled automatically reduces motor current to 50% of set value after the last step is made. The driver has built-in features to indicate power on (Green LED) and Clocks being received (Yellow LED). The MBLA05101 has a fixed step resolution of 2000 steps per revolution with a 200 step/revolution stepper motor and the bipolar drive configurations handles 4, 6, and 8 lead motors. The MLA05101 has an internal fuse that can power bipolar stepper motors upto 425W.

Optically Isolated Input Pin Descriptions

The inputs of the MLA05101 are optically isolated with the anode (+) and cathode (-) both brought out to the user. With no current going through the opto-diode the input is considered high. To enable the input a minimum of 1.0 mA needs to be sourced or sunked through the opto-diode. This is done simply by placing a voltage of +3.5 to +8.6VDC across the two inputs of the opto-diode. If sourcing current into the inputs, then all three cathodes (-) should be tied together and grounded as shown in Figure 3. If sinking current, then all three anodes (+) should be tied together to the +voltage as shown in Figure 4.

To enable an input, apply a DC voltage source of +5VDC to 8.6VDC across the inputs. The Anodes (+) are pins 1, 3, and 5 and the Cathodes (-) are pins 2, 4, and 6.

Connecting the Step Motor

Phase 1 and 3 of the Step Motor is connected between pins 2 and 3 on terminal block connector TB3. Phase 2 and 4 of the Step Motor is connected between pins 4 and 5 on terminal block connector TB3. Refer to Figures 3 & 4 for Typical Application Hook-Up.

NOTE: The physical direction of the motor with respect to the direction input will depend on the connection of the motor windings. To reverse the direction of the motor with respect to the direction input, swap the wires on Phase 1 and Phase 3.

WARNING: Do not connect or disconnect motor wires while power is applied! This driver does not protect itself if the motor is disconnect while powered.

Terminal Blocks Description

Pin #	Description
1	Clock+ : Step Clock Input Anode (+) - A positive going edge on this isolated input advances the motor one increment. The size of the increment is dependent on the Microstep Select Inputs of Switch 1.
2	Clock- : Step Clock Input Cathode (-)
3	Dir+ : Direction Anode (+) - This isolated input is used to change the direction of the motor. Physical direction also depends on the connection of the motor windings.
4	DIR- : Direction Cathode (-)
5	ON/OFF : On/Off Anode (+) - This isolated input is used to enable and disable the output section of the driver. When HIGH (open) the outputs are enabled. However, this input does not inhibit the step clock.
6	ON/OFF : On/Off Cathode (-)

Table 1: Pin Descriptions for Terminal Block 1

Pin #	Description
1	Motor Ground
2	A : Phase 1 of the Step Motor
3	Ā : Phase 3 of the Step Motor
4	B : Phase 2 of the Step Motor
5	B : Phase 4 of the Step Motor

Table 2: Pin Descriptions for Terminal Block 2

Pin #	Description
1	AC IN: HOT
2	AC IN: NEUTRAL
3	EARTH GROUND

Table 3: Pin Descriptions for Terminal Block 3

Power Supply Requirements

The MLA05101 has an input line voltage ranging from 90-132VAC. TB3 pin 1 is used as the hot terminal and is internally fused, TB3 pin 2 is used as the neutral terminal and TB3 pin 3 is the EGND terminal. The EGND terminal must be connected. The MLA05101 is equipped with an internal 5A fuse to restrict excessive power consumption. The MLA05101 can power bipolar stepper motors upto 425W.

****NOTE: The 10EMC1 Filter may be required to purchase and placed at the power input of the MLA05101 driver.**

The AC line filter can help to keep external transients and spikes on the power line from entering the driver voltage input lines. This type of interference can be caused by other AC powered devices being turned on and off and by motors running on the the same power subsystem. The series inductance and capacitance line-to-line and line-to-neutral that is built into the 10EMC1 filter can attenuate the transients so that they do not upset sensitive circuitry inside the MLA05101.

Part #	Description
PWR-10EMC1	Dual Stage RFI Power Line Filter
LIN-AA4254	110 Volt Line cord with DNF18-250-FIB connectors (when using the PWR-10EMC1)

Table 4: AC Line filter ordering information

Absolute Maximum Ratings

Input Voltage: 132VAC

Output Current: 5.0 Amps Peak

Maximum Power Output: 425W

Max Plate Temperature: 70°C

Storage Temperature: 0° to +50°C

Hi-Pot Rating (10 seconds): Line to Ground 1200VAC, 10mA

Electrical Specifications

Item	Min	Typ	Max	Units
Input Voltage	90	110	132	VAC
Phase Output Current	0.53		3.53	A (RMS)
Phase Output Current	0.75		5.0	A (PEAK)
Input Voltage (Inputs)	3.5		8.6	VDC
Clock Frequency	0		100	kHz
Chopping Frequency	27	30	33	kHz
Operation Temperature	0		80	C

Table 5: MBC12101 Electrical Specifications

Setting the Output Current

WARNING: Do not set the current setting above the step motors rated current. When using a higher current into a motor, the motor will overheat and burnup. Should this occur, the driver will also be damaged.

The output current on the MLA05101 is set by an onboard potentiometer. This potentiometer determines the per phase peak output current of the driver. The relationship between the output current and the potentiometer value is as follows:

Peak Current	Potentiometer Setting	Peak Current	Potentiometer Setting
0.75A	0%	3.5A	60%
1.15A	10%	3.95A	70%
1.55A	20%	4.35A	80%
2.0A	30%	4.8A	90%
2.5A	40%	5A	100%
3.0A	50%	--	--

Table 6: Potentiometer values with respect to the output current

Reducing Output Current

Reducing the output current occurs approximately 1 second after the last positive going edge of the step clock input. The amount of current per phase in the reduction mode is approximately 50% of the set current. Reducing the output current is accomplished when no current flows through the opto-diode at the CLOCK (+) and CLOCK (-) pins after the last step has occurred. The clock LED should be off at this time.

Wiring Diagrams

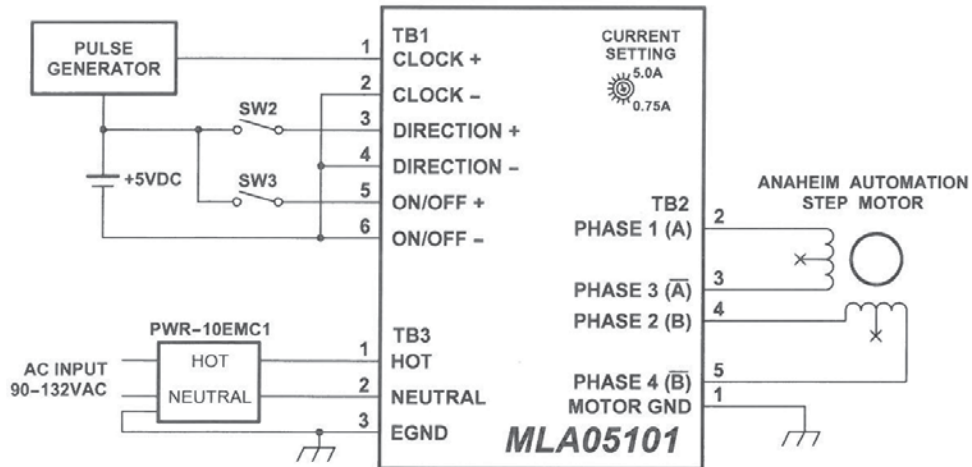

Table 7: Hook up for current sourcing inputs

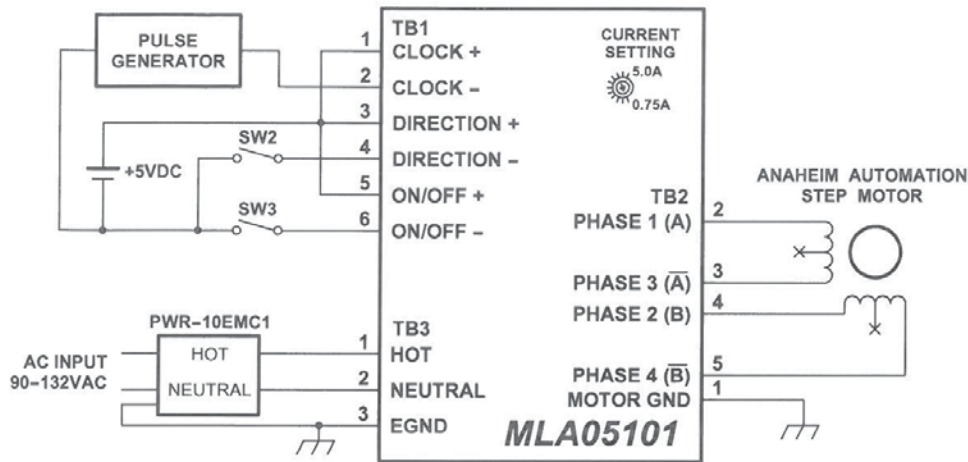

Table 8: Hook up for current sinking inputs

Dimensions

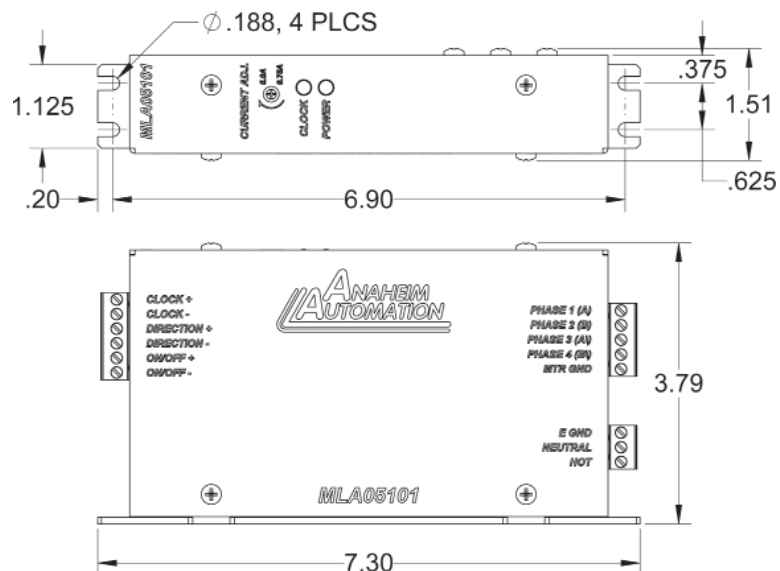

Table 9: MBC12101 Dimensions

Motor Selection

The MLA05101 is a Bipolar Microstep driver that is compatible with both Bipolar and Unipolar Stepper Motor Configurations, (i.e. 8 and 4 lead motors, and 6 lead center tapped motors).

Stepper Motors with low current ratings and high inductance will perform better at low speeds, providing higher low-end torque. Motors with high current ratings and low inductance will perform better at higher speeds, providing more high-end torque. Higher voltages will cause the current to flow faster through the motor coils. This in turn means higher step rates can be achieved. *Care should be taken not to exceed the maximum voltage of the driver. There is an internal fuse of 5A in the driver. Care must be taken to not exceed 425W.*

Since the MLA05101 is a constant current source, it is not necessary to use a stepper motor that is rated at the same voltage as the supply voltage. What is important is that the MLA05101 is set to the appropriate current level based on the motor being used. Refer to the following chart for setting the current potentiometer based on the current code in the part number of the motor. Examples of motor part numbers are shown below. Anaheim Automation offers a comprehensive line of step motors in 08, 11, 14, 15, 17, 23, 24, 34 and 42 frame sizes. Contact the factory to verify motor compatibility with the MLA05101.

Step Motor Current Setting Guide

Motor Example	Motor Current Number Code	Unipolar Rating	Series Peak Rating	Parallel Peak Rating	Series Current Setting	Parallel Current Setting
24Y504-LW8	04	2.0A	2.0A	4.0A	30%	70%
34Y004-LW8	04	2.0A	2.0A	4.0A	30%	70%
34Y104-LW8	04	2.0A	2.0A	4.0A	30%	70%
24Y506-LW8	06	3.0A	3.0A	6.0A	50%	---
34Y006-LW8	06	3.0A	3.0A	6.0A	50%	---
34Y106-LW8	06	3.0A	3.0A	6.0A	50%	---
34Y207-LW8	07	3.5A	3.5A	7.0A	60%	---
34Y307-LW8	07	3.5A	3.5A	7.0A	60%	---
34Y008-LW8	08	4.0A	4.0A	8.0A	70%	---
34Y108-LW8	08	4.0A	4.0A	8.0A	70%	---
34Y010-LW8	10	5.0A	5.0A	10.0A	100%	---

Table 10: Table selection for Anaheim Automation motor current settings.

***Anaheim Automation offers motor cable, making hook-ups quick and easy!
Contact the factory or visit our website for more motor and cable offerings.***

Setting the Output Current

The output current for the stepper motor being used when microstepping is determined differently from that of a full/half step unipolar driver. In the MLA05101, a sine/cosine output function is used in rotating the motor. The output current for a given motor is determined by the motors current rating and the wiring configuration of the motor. There is a current adjustment potentiometer used to set the output current of the MLA05101. This sets the peak output current of the sine/cosine waves. The specified motor current (which is the unipolar value) is multiplied by a factor of 1.0, 1.4, or 2.0 depending on the motor configuration (series, half-coil, or parallel).

WARNING: Do not set the current setting above the step motors rated current. When using a higher current into a motor, the motor will overheat and burnup. Should this occur, the driver will also be damaged.

Stepper Motor Configurations

Stepper Motors can be wired with 4, 6, or 8 leads. Each configuration requires different currents. Refer to the lead configurations and the procedures to determine their output current.

WARNING: Step motors will run hot even when configured correctly. Damage may occur to the motor if a higher than specified current is used. Most specified motor currents are maximum values. Care should be taken to not exceed these ratings.

6 Lead Motors

When configuring a 6 lead motor in a **half-coil configuration** (connected from one end of the coil to the center tap), multiply the specified per Phase (or unipolar) current rating by 1.4 to determine the current setting potentiometer value. This configuration will provide more torque at higher speeds when compared to the series configuration.

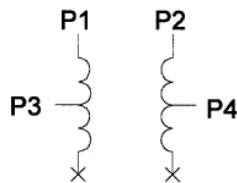

When configuration the motor in a **series configuration** (connected from end to end with the center tap floating) use the specified per Phase (or unipolar) current rating to determine the current setting potentiometer value.

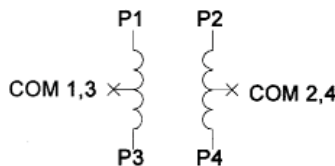

4 Lead Motors

Multiply the specified **series** motor current by 1.4 to determine the current adjustment potentiometer value. Four Lead Motors are usually rated with their appropriate series current, as opposed to the *Phase Current*, which is the rating for 6 and 8 lead motors.

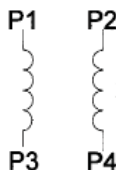

8 Lead Motors

Series Connection: When configuring the motor windings in series, use the per Phase (or unipolar) current rating to determine the current setting potentiometer value.

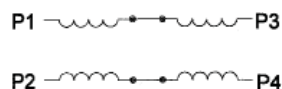

Parallel Connection: When configuring the motor windings in parallel, multiply the per Phase (or unipolar) current rating by 2.0 to determine the current setting potentiometer value.

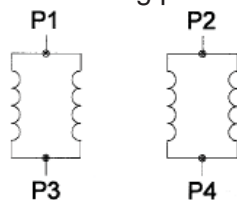

Torque Curves

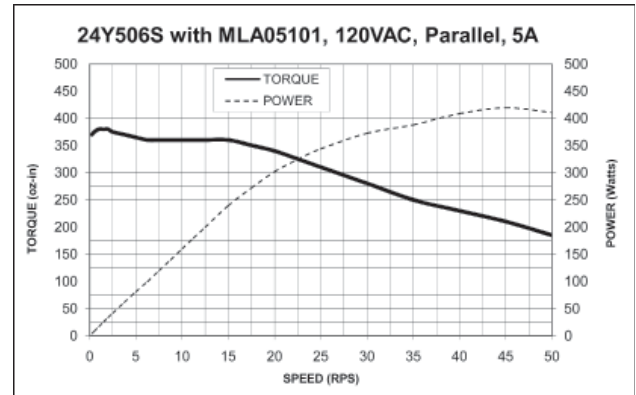
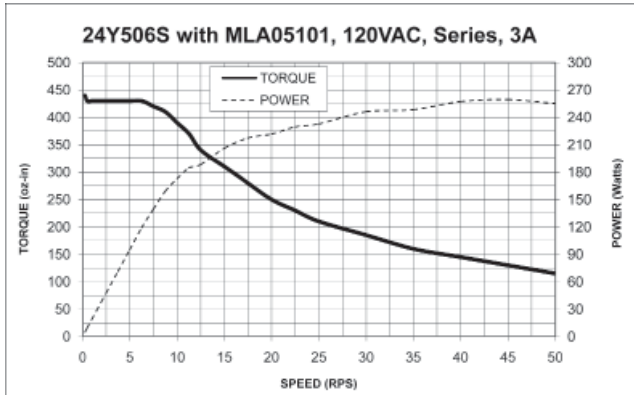

COPYRIGHT

Copyright 2016 by Anaheim Automation. All rights reserved. No part of this publication may be reproduced, transmitted, transcribed, stored in a retrieval system, or translated into any language, in any form or by any means, electronic, mechanical, magnetic, optical, chemical, manual, or otherwise, without the prior written permission of Anaheim Automation, 4985 E Landon Drive, Anaheim, CA 92807.

DISCLAIMER

Though every effort has been made to supply complete and accurate information in this manual, the contents are subject to change without notice or obligation to inform the buyer. **In no event will Anaheim Automation be liable for direct, indirect, special, incidental, or consequential damages arising out of the use or inability to use the product or documentation.**

Anaheim Automation's general policy does not recommend the use of its' products in life support applications wherein a failure or malfunction of the product may directly threaten life or injury. Per Anaheim Automation's Terms and Conditions, the user of Anaheim Automation products in life support applications assumes all risks of such use and indemnifies Anaheim Automation against all damages.

LIMITED WARRANTY

All Anaheim Automation products are warranted against defects in workmanship, materials and construction, when used under Normal Operating Conditions and when used in accordance with specifications. This warranty shall be in effect for a period of twelve months from the date of purchase or eighteen months from the date of manufacture, whichever comes first. **Warranty provisions may be voided if products are subjected to physical modifications, damage, abuse, or misuse.**

Anaheim Automation will repair or replace at its' option, any product which has been found to be defective and is within the warranty period, provided that the item is shipped freight prepaid, with previous authorization (RMA#) to Anaheim Automation's plant in Anaheim, California.

TECHNICAL SUPPORT

If you should require technical support or if you have problems using any of the equipment covered by this manual, please read the manual completely to see if it will answer the questions you have. If you need assistance beyond what this manual can provide, contact your Local Distributor where you purchased the unit, or contact the factory direct.

ANAHEIM AUTOMATION